

# *RX72 Shelbourne Header*

*Rice Special*

**PARTS MANUAL**

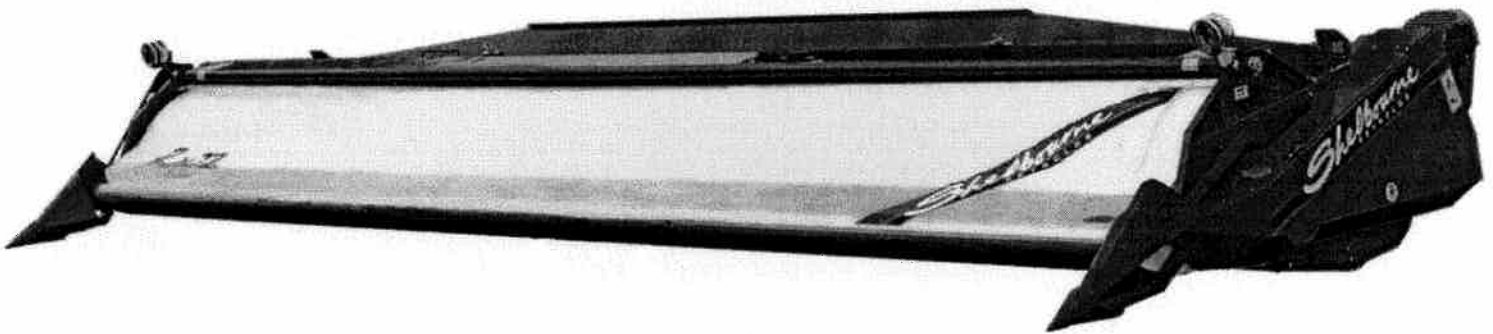

*Shelbourne*  
REYNOLDS

Shelbourne Reynolds Engineering Ltd  
Stanton  
Bury St Edmunds  
Suffolk IP31 2AR  
England  
Telephone: 01359 250415  
Fax. No: 01359 250464

(Stores direct 01359 251231)  
(Stores direct 01359 252031)



INVESTOR IN PEOPLE

**ISSUE..3**  
**16.8.2002**



## **SHELBOURNE HEADER PARTS MANUAL**

Your *Shelbourne* Header is designed to fit many different types of combine.

For this reason the machine number index is broken down into sections for identification. Your serial and machine numbers are listed below:

SHELBOURNE HEADER SERIAL NUMBER \_\_\_\_\_

SHELBOURNE HEADER MACHINE NUMBER \_\_\_\_\_

ADAPTOR PLATE ASSEMBLY \_\_\_\_\_

DRIVE KIT \_\_\_\_\_

HYDRAULIC FITTING KIT \_\_\_\_\_

OTHER KIT OPTIONS \_\_\_\_\_

\_\_\_\_\_  
\_\_\_\_\_  
\_\_\_\_\_

This manual contains all parts common to the *Shelbourne* Header and is used in conjunction with the combine fittings manual, which contains the adaptor plate, and drive kit parts and fitting, and any other options available.

### **MACHINE IDENTIFICATION**

The *Shelbourne* Header machine identification number is engraved on a plate on the top right hand corner of the header.

The adaptor plate has a plate on the top right hand corner also with the adaptor plate assembly number engraved on it.

The drive kit can be identified by description, and use of the drive kit identification number marked above.

## ORDERING SPARE PARTS

To ensure that you order the correct part from your SRE dealer please use the following procedure.

### ALWAYS QUOTE THE MACHINE AND SERIAL NUMBERS WHEN ORDERING.

Refer to the front of this parts list book (machine assemblies), decide if the part you want is on:

*Shelbourne* Head  
Adaptor Kit  
Drive Kit

If your part is on the Adaptor Kit, identify by matching the part number from the adaptor plate with that in the top left hand corner of the parts lists. You will find the appropriate drawing accompanying the parts list.

If the part you require is on the drive kit, ensure that you have the parts listing for the correct combine model and width. Then progress through to the next drawing following that list, for indication of that part.

If the part you require is on the *Shelbourne* Head assembly, identify the appropriate assembly by matching the part number from the *Shelbourne* Head with the page with the same number marked on the top left hand side.

Use the following sub assembly numbers and descriptions to find the area of the machine that your part is required, i.e. you need a part which is fitted to the auger, your part will be in the auger assembly parts list.

Having decided which sub-assembly your part should be under, use the number beside that sub-assembly description which will begin with 1960-- -- to find the parts listing of the sub-assembly further on in the manual. The number will be printed in the top left hand corner, the sub-assemblies are in numerical order.

Having found the correct parts list, you will find the corresponding drawing by processing through the manual to the next drawing.

The drawings indicate the components by item numbers which you will find are repeated in the left hand side of your parts listing, and therefore referring to the correct part.

If the item within the sub-assembly is a further collection of parts (i.e. a KIT within a sub assembly) then the parts listing for this will be found just after the 1960-- -- sub-assemblies. These smaller assemblies will be in alphabetical and numerical order.



**Shelbourne Reynolds Engineering Limited**

ASSY NUMBER: 196553 12		ASSY DESCRIPTION: RX72 RICE SPECIAL HEADER (1999)					
ITEM	PART NO	DESCRIPTION	QTY	ITEM	PART NO	DESCRIPTION	QTY
1	196186 12	FRAME & PARTS	1				
2	196141 32	AUGER ASSY	1				
3	196102 04	AUGER MTG SUB	1				
4	196067 02	DRIVE COMPONENTS	1				
5	196123 12	SHAKERPAN SUB	1				
6	196097 14	STRIPPING ROTOR ASSY RH	1				
7	196097 15	STRIPPING ROTOR ASSY LH	1				
8	196144 01	ROTOR MTG SUB	1				
9	196181 02	ROTOR/AUGER DRIVE SUB	1				
10	196140 12	HYDRAULICS	1				
11	RDS-0005	HEADER MONITORING KIT	1				
12	196120 32	HOOD SUB ASSY	1				
13	196053 52	ADJ CROP DEFLECTOR SUB	1				
14	196183 01	EMBLEMS & GUARDS	1				
15	196078 01	TORPEDO DIVIDER SUB	1				
OR	196132 01	SHORT DIVIDER SUB	1				
16	RDS-0001	COMBINE MONITOR KIT	1				
17	196143 12	HEADER LIGHTS SUB (USA ONLY)	1				

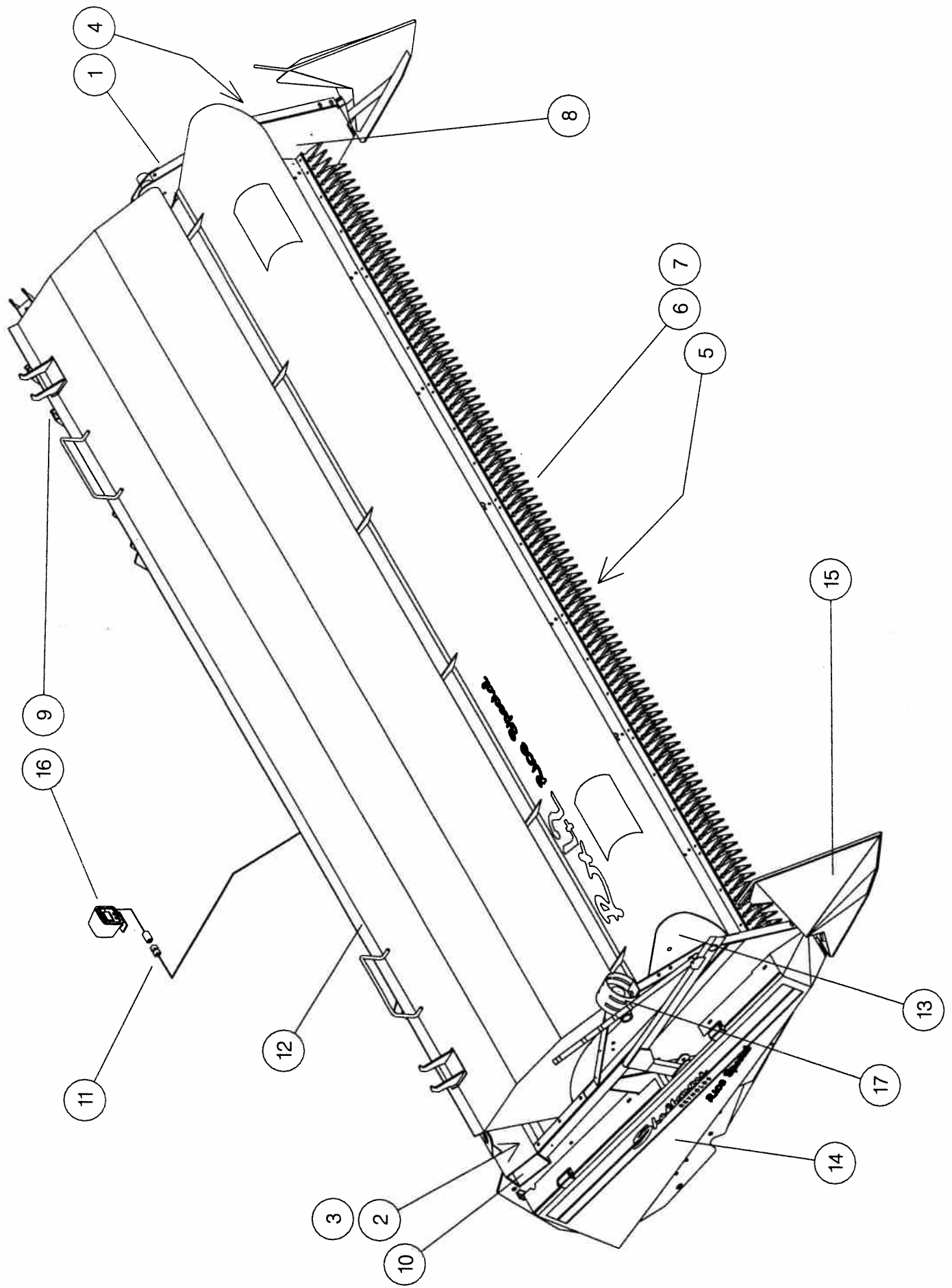

**Shelbourne Reynolds Engineering Limited**

ASSY NUMBER: 196053 52		ASSY DESCRIPTION: ADJ.CROP DEFLECTOR SUB ASSY (RX72)					
ITEM	PART NO	DESCRIPTION	QTY	ITEM	PART NO	DESCRIPTION	QTY
1	192686 02	ADJ.CROP DEF	1				
2	190361 01	PIVOT BUSH	2				
3	195154 01	SEAL STRIP	2				
4	192038 01	CLAMP STRIP	2				
5	POP-0006	POP RIVET	16				
6	191642 01	ROLLER	2				
7	191981 01	EMBLEM	1				
8	192524 09	EMBLEM	1				
9	192718 01	TRANSFER	1				
10	190119 05	PLAIN WASHER	2				
11	WSH-0058	WASHER	2				
12	HSS-0140	SETSCREW	2				
13	193838 02	EMBLEM	1				
14	195140 01	FRONT CLAMP STRIP	2				

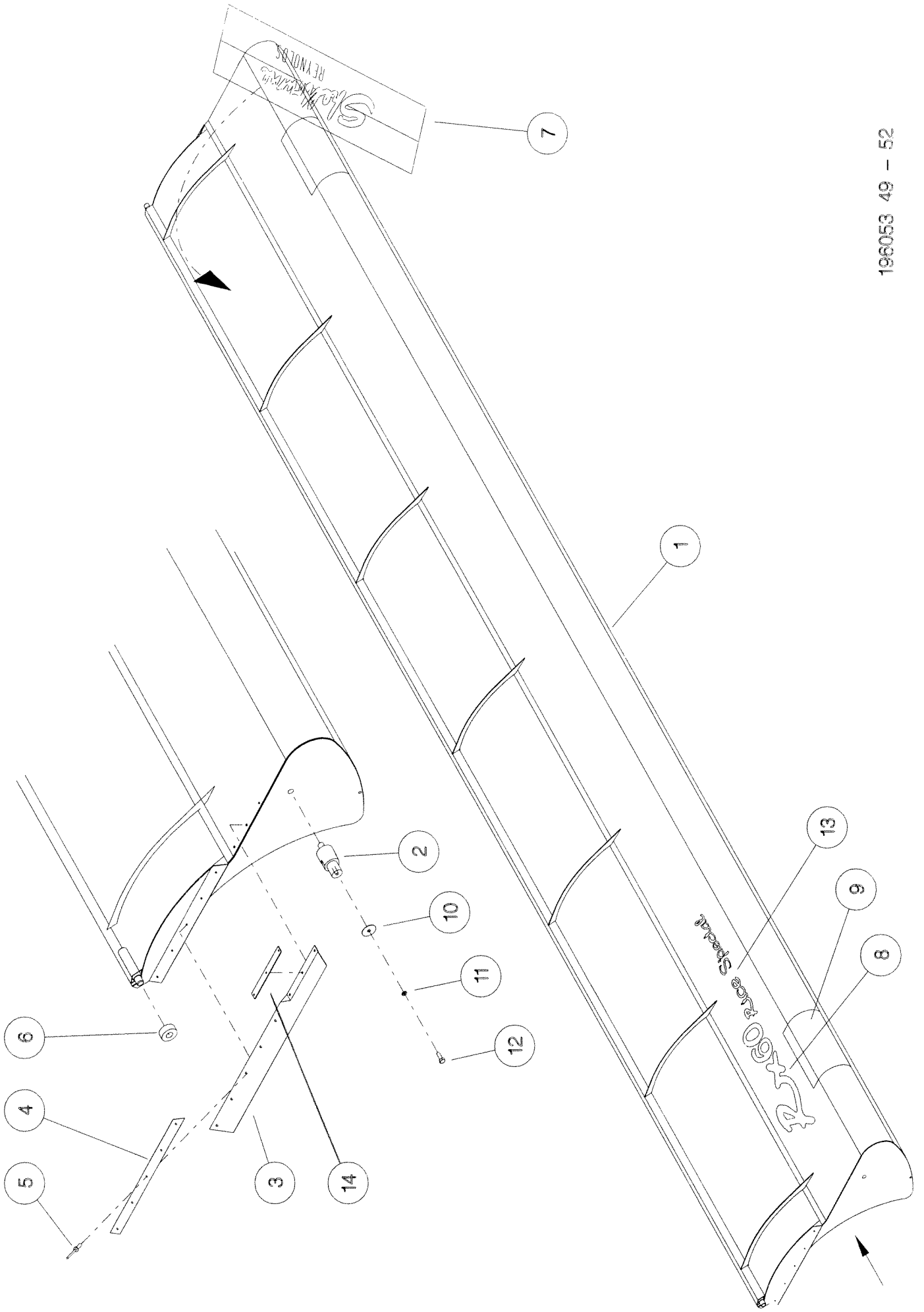

**Shelbourne Reynolds Engineering Limited**

ASSY NUMBER: 196067 02		ASSY DESCRIPTION:DRIVE PARTS SHAKERPAN STD			QTY	DESCRIPTION	PART NO	ITEM	QTY
ITEM	PART NO	DESCRIPTION							
1	191777 01	IDLER ADJ SCREW			1				
2	WSH-0018	WASHER			1				
3	191774 01	PLATE			1				
4	NUT-0269	NUT			1				
5	191040 01	SPACER			1				
6	131014 01	SPROCKET IDLER			1				
7	BRG-1995	BEARING			1				
8	CIR-0470	CIRCLIP			1				
9	190060 06	IDLER SPINDLE			1				
10	192258 01	PAN DRIVE SPROCKET 25T			1				
11									
12	K0807035	KEY			1				
13	CIR-1125	CIRCLIP			1				
14	BRG-1994	BEARING			2				
15	192263 01	PAN DRIVE SHAFT			1				
16	BSHZ02553	LOCKING BUSH			1				
17	192265 01	PITMAN			1				
18	BRG-22500	BEARING			2				
19	HSS-0086	SETSCREW			6				
20	WSH-0009	FLAT WASHER			6				
21	NUT-0260	NUT			6				
22	HSS-0318	SETSCREW			1				
23	WSH-0070	SPRING WASHER			1				
24	BLT-2316	BOLT			1				
25	WSH-0024	FLAT WASHER			1				
26	NUT-0271	NUT			1				
27	192344 01	SPACER			1				
28	CHN-01682	CHAIN + JOINER			1				
28a	CHN-01600	CHAIN JOINER LINK			1				

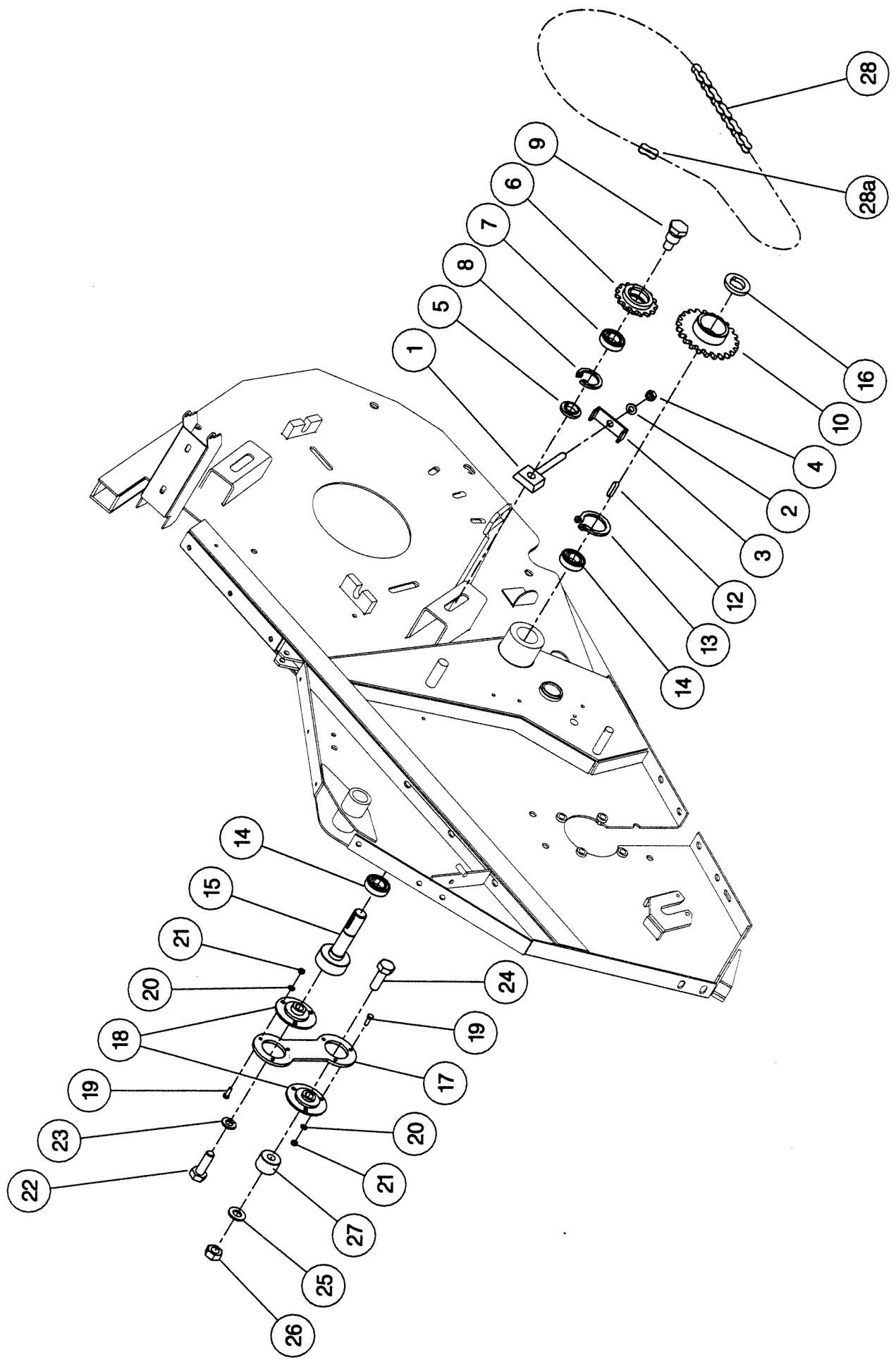

**Shelbourne Reynolds Engineering Limited**

ASSY NUMBER: 196078 01		ASSY DESCRIPTION: TORPEDO DIVIDERS FOR RX & CX MACHINES					
ITEM	PART NO	DESCRIPTION	QTY	ITEM	PART NO	DESCRIPTION	QTY
1	192533 01	DIVIDER ARM LH	1				
2	192533 02	DIVIDER ARM RH	1				
3	192537 01	DIVIDING PLATE LH	1				
4	192537 02	DIVIDING PLATE RH	1				
5	191770 01	NOSE CONE	2				
6	191862 01	SHOE	2				
7	HSS-0191	SETSCREW	8				
8	NUT-0265	NUT	8				
9	WSH-0015	WASHER	8				
10	HSS-0155	BOLT	2				
11	WSH-0058	WASHER	2				

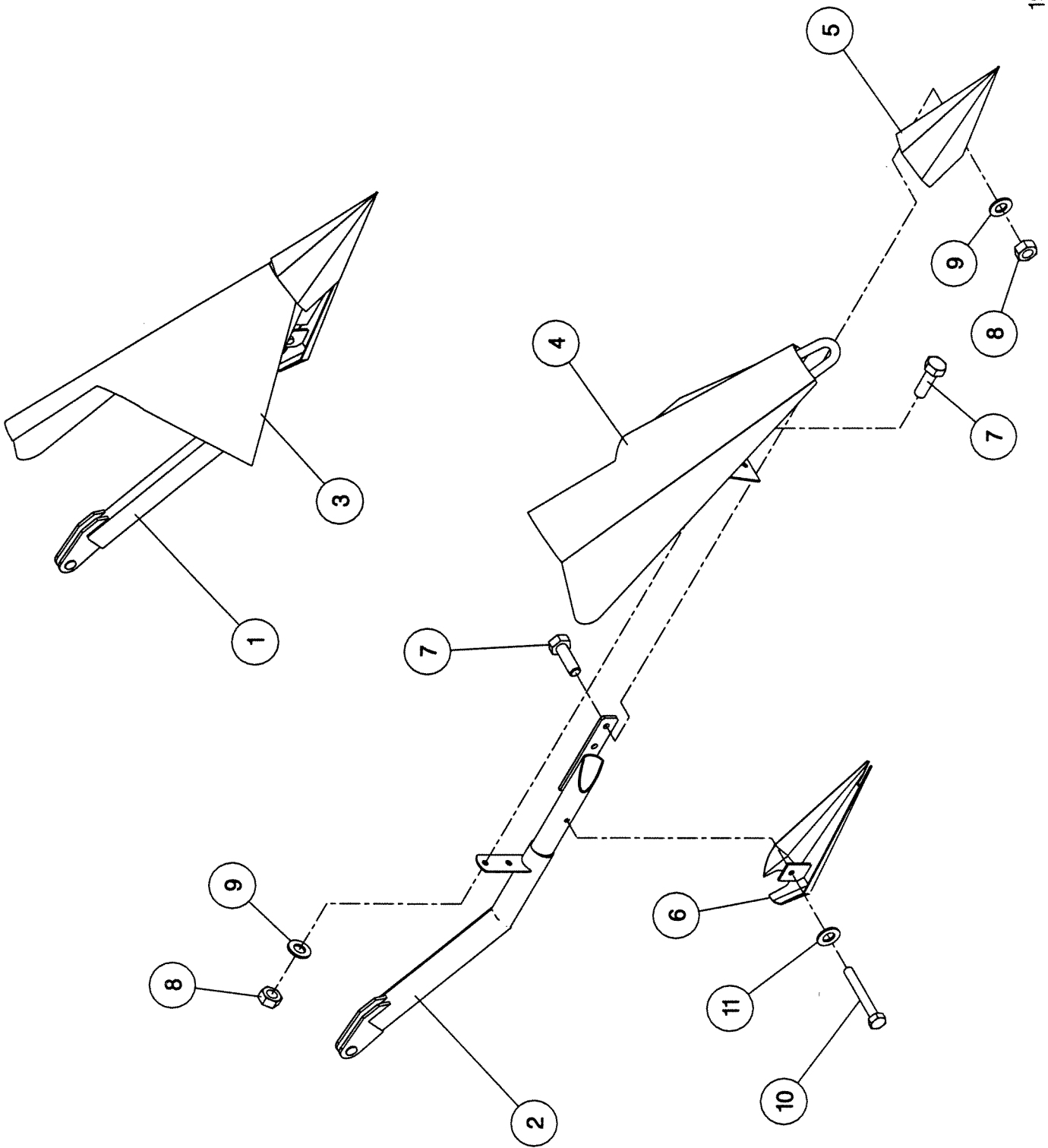



**Shelbourne Reynolds Engineering Limited**

ASSY NUMBER: 196097 14		ASSY DESCRIPTION: STRIPPING ROTOR ASSY (R/H) 3.6m					
ITEM	PART NO	DESCRIPTION	QTY	ITEM	PART NO	DESCRIPTION	QTY
1	192892 01	OUTER HUB CASTING L.H.	1				
2	192892 02	OUTER HUB CASTING R.H.	1				
3	192892 03	INNER HUB CASTING	5				
4	192890 03	ROTOR SECTION 3.6M	7				
5	HSSG10204	SET SCREW	124				
6	191968 02	ELITE ELEMENT	48				
OR	193087 01	ELITE ELEMENT (SLOTTED)	48				
OR	193558 01	STANDARD ELEMENT (SEED SAVE)	48				
7	192291 01	ANTI WEAR STRIP CTR.	40				
OR	192291 07	S-TYPE STRIP CTR	40				
OR	193780 01	SEED SAVER FINGER CTR.	40				
8	192291 02	ANTI WEAR STRIP END	8				
OR	192291 08	S-TYPE STRIP END	8				
OR	193782 02	SEED SAVER FINGER RH END	8				
9	192291 03	ANTI WEAR STRIP CTR END	8				
OR	192291 09	S-TYPE STRIP CTR END	8				
OR	193781 01	SEED SAVER RH CTR END	8				
10	191865 02	CENTRE FINGER RH (RICE)	8				
OR	194109 02	CENTRE FINGER RH (CEREALS)	8				
11	HSSF08174	SET SCREW	208				
12	192679 01	ANTI WRAP PLATE	8				
13	WSH-1034	PENNY WASHER	16				
14	SCW-5180	SELF TAP. SCREW	16				
15							
16							
17	KIT-00976	BALL COUPLING KIT	1				
18	192899 01	IDLE SHAFT W/ASSY	1				
19	192959 01	OUTER CLAMP RING (HALF)	4				
20							
21							
22	193117 03	ROTOR SECTION 3.6M (HOLE)	1				
23	BPG-00200	BODY PLUG	1				

**Shelbourne Reynolds Engineering Limited**

ASSY NUMBER: 196097 15		ASSY DESCRIPTION: STRIPPING ROTOR ASSY (L/H) 3.6m					
ITEM	PART NO	DESCRIPTION	QTY	ITEM	PART NO	DESCRIPTION	QTY
1	192892 01	OUTER HUB CASTING L.H.	1				
2	192892 02	OUTER HUB CASTING R.H.	1				
3	192892 03	INNER HUB CASTING	5				
4	192890 03	ROTOR SECTION 3.6M	8				
5	HSSG10204	SET SCREW	124				
6	191968 02	ELITE ELEMENT	48				
OR	193087 01	ELITE ELEMENT (SLOTTED)	48				
OR	193558 01	STANDARD ELEMENT (SEED SAVE)	48				
7	192291 01	ANTI WEAR STRIP CTR.	40				
OR	192291 07	S-TYPE STRIP CTR	40				
OR	193780 01	SEED SAVER FINGER CTR.	40				
8	192291 02	ANTI WEAR STRIP END	8				
OR	192291 08	S-TYPE STRIP END	8				
OR	193782 01	SEED SAVER FINGER LH END	8				
9	192291 03	ANTI WEAR STRIP CTR END	8				
OR	192291 09	S-TYPE STRIP CTR END	8				
OR	193781 02	SEED SAVER LH CTR END	8				
10	191865 01	CENTRE FINGER LH (RICE)	8				
OR	194109 01	CENTRE FINGER LH (CEREALS)	8				
11	HSSF08174	SET SCREW	208				
12	192679 01	ANTI WRAP PLATE	8				
13	WSH-1034	PENNY WASHER	16				
14	SCW-5180	SELF TAP. SCREW	16				
15	193103 01	CENTRE SHAFT W/ASSY	1				
16	192897 01	DRIVE SHAFT W/ASSY	1				
17							
18							
19	192959 01	OUTER CLAMP RING (HALF)	4				
20							
21							
22							
23							
24	PIN-1779	ROLL PIN	1				

3.0 METRE R.H ROTOR ILLUSTRATED

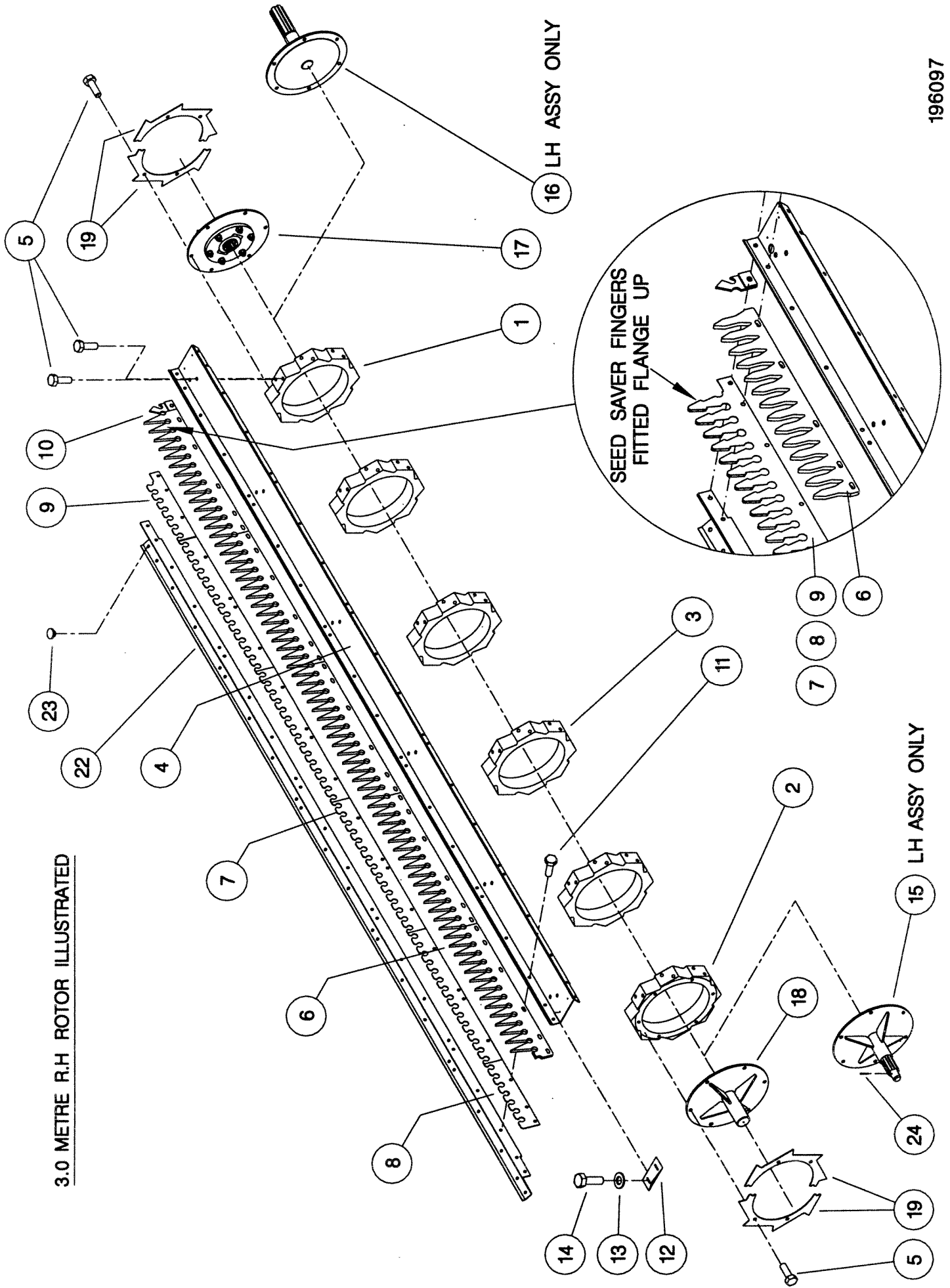

**Shelbourne Reynolds Engineering Limited**

ASSY NUMBER: 196102 04		ASSY DESCRIPTION: AUGER MOUNTING/DRIVE KIT (RX) 1996					
ITEM	PART NO	DESCRIPTION	QTY	ITEM	PART NO	DESCRIPTION	QTY
1	200035 03	SUPPORT PLATE L.H.	1				
2	BRG-0240	BEARING	1				
3	BLT-3745	COACH BOLT	3				
4	WSH-0015	PLAIN WASHER	3				
5	NUT-0265	NYLOC NUT	3				
6	BLT-3790	COACH BOLT	4				
7	192636 06	VERTICAL ADJUSTER	2				
8	192636 01	HORIZONTAL ADJUSTER	2				
9	WSH-0018	PLAIN WASHER	14				
10	NUT-0269	NYLOC NUT	5				
11	NUT-0170	PLAIN NUT	8				
12	K0807050	KEY	1				
13	KIT-00115	AUGER SLIP CLUTCH (SEE PARTS LIST KIT-00115)	1				
14	WSH-0030	PLAIN WASHER	1				
15	NUT-0580	CASTLE NUT	1				
16	PIN-1150	SPLIT PIN	1				
17	200038 01	SUPPORT PLATE R.H.	1				
18	K0807060	KEY	1				
19	200120 03	ADJUSTER ASSY	1				
20	SCW-4535	GRUB SCREW	2				
21	HSS-0241	SET SCREW	1				

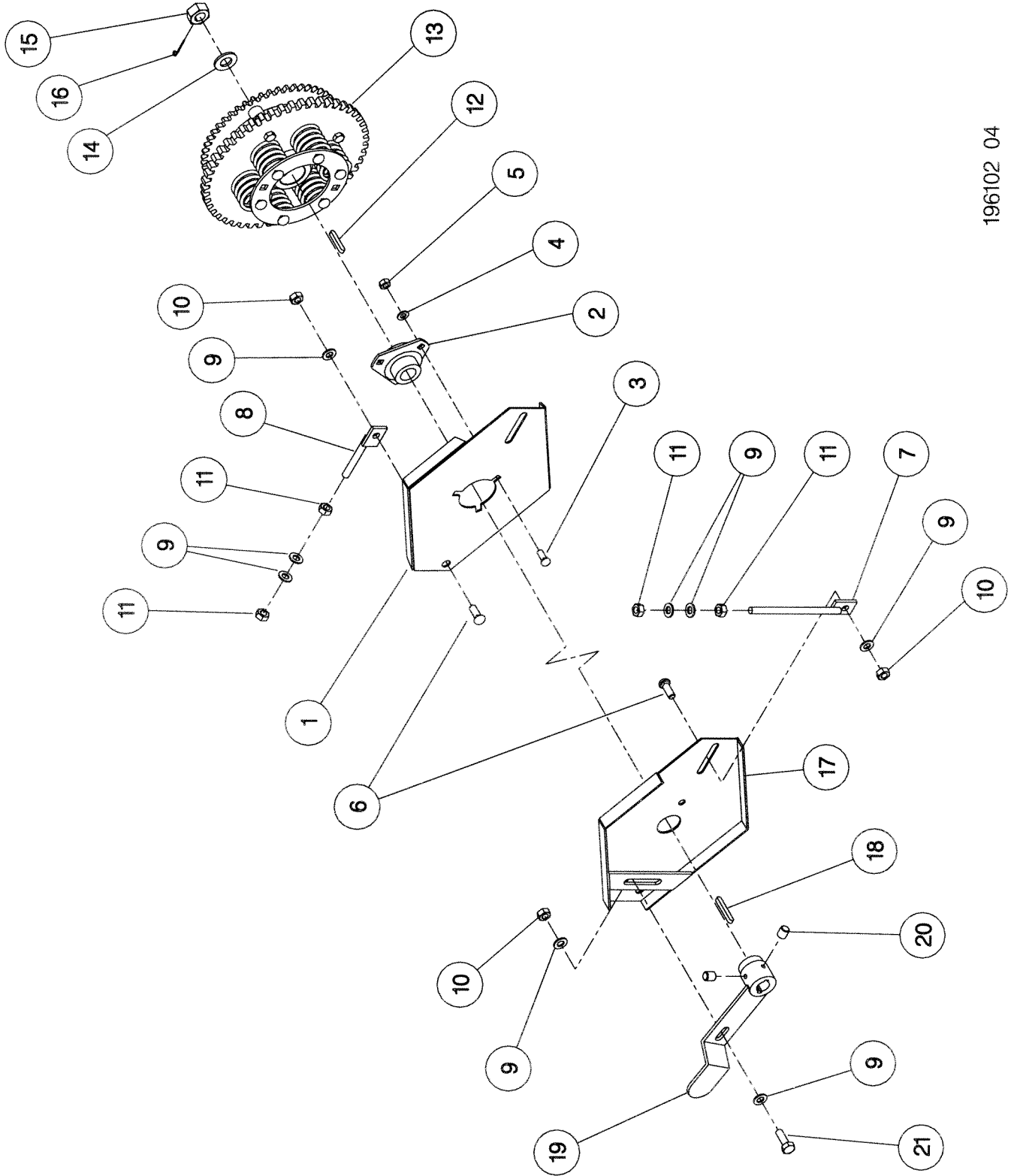

196102 04

**Shelbourne Reynolds Engineering Limited**

ASSY NUMBER: 196120 32		ASSY DESCRIPTION: TOP DOOR COWL ASSY-STAINLESS (RX72)					
ITEM	PART NO	DESCRIPTION	QTY	ITEM	PART NO	DESCRIPTION	QTY
1	193289 13	COWL ASSY-STAINLESS (RX72)	1				
2	BSH-3030	BUSH	2				
3	192813 01	LARGE WASHER	2				
4	192812 01	COWL PIN	2				
5	NIP-0001	GREASE ZERK	2				
6	GSTA14406	GAS STRUTT	2				
7	WSH-0061	WASHER	2				
8	WSH-0015	WASHER	2				
9	NUT-0265	NUT	2				
10	BLTA10290	BOLT	4				
11	EDS-11600	SEAL STRIP	7.2m				
12	192718 01	TRANSFER (NO STEP)	2				

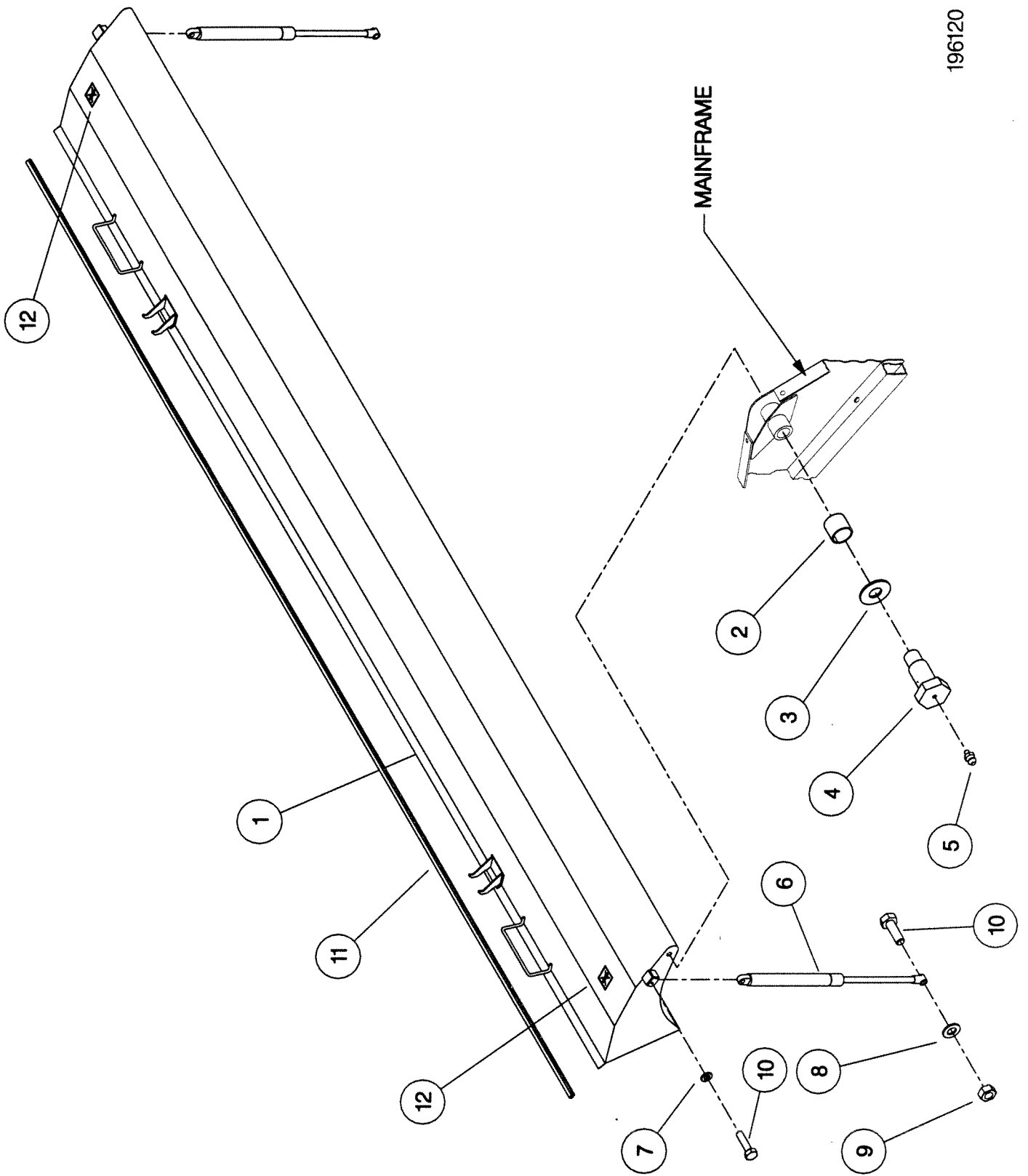

196120

**Shelbourne Reynolds Engineering Limited**

ASSY NUMBER: 196123 12		ASSY DESCRIPTION: SHAKER PAN SUB (RX72 - 1997)					
ITEM	PART NO	DESCRIPTION	QTY	ITEM	PART NO	DESCRIPTION	QTY
1	192732 01	TORSION TUBE L.H (3.6M)	1	38	BLT-2090	BOLT	2
2	193137 01	TORSION TUBE R.H (3.6M)	1	39	HSS-0084	SET SCREW	2
3	BSH-1530	RUBBER BUSH INSERT	6	40	WSH-0056	SPRING WASHER	8
4	HSS-0191	SETSCREW	2	41			
5	NUT-0265	NYLOC NUT	10	42	192738 02	OUTER SEAL STRIP	2
6	WSH-0015	FLAT WASHER	14	43	192969 01	RETAINER	6
7	BRG-1995	BEARING	2	44	192970 01	TUBE	6
8	HSS-0315	SET SCREW	2	45	PSP-01201	PLASTIC SPACER	12
9	WSH-0070	SPRING WASHER	2	46	193293 01	COVER PLATE	1
10	WSH-0024	PLAIN WASHER	2	47	HSS-0084	SET SCREW	4
11			2	48	192970 02	TUBE	6
12				49	PSP-01800	PLASTIC SPACER	24
13	192264 02	CLAMP BLOCK TOP	2	50	BLTA08530	BOLT	6
14	BLT-2197	BOLT	4	51	WSH-1038	PENNY WASHER	12
15	WSH-0061	SPRING WASHER	4				
16	192266 01	PIVOT BLOCK (PAIR)	4				
17							
18	BLT-2209	BOLT	4				
19	HSSA10680	SETSCREW	4				
20							
21	193309 01	SHAKER PAN ASSY R.H (3.6M)	1				
22	193310 01	SHAKER PAN ASSY L.H (3.6M)	1				
23	SPGA32221	SPRING	6				
24	BLTA08500	BOLT	6				
25							
26	WSH-0012	WASHER	12				
27	NUT-0263	NUT	12				
28	192738 01	SEAL STRIP	2				
29	192273 01	CLAMP STRIP	12				
30	BLT-2110	BOLT	48				
31	WSH-0009	FLAT WASHER	52				
32	NUT-0260	NYLOC NUT	48				
33	HSS-0265	SET SCREW	6				
34	WSH-0018	PLAIN WASHER	6				
35	NUT-0269	NYLOC NUT	6				
36	192355 01	END DEFLECTOR R.H.	1				
37	192354 01	END DEFLECTOR L.H.	1				

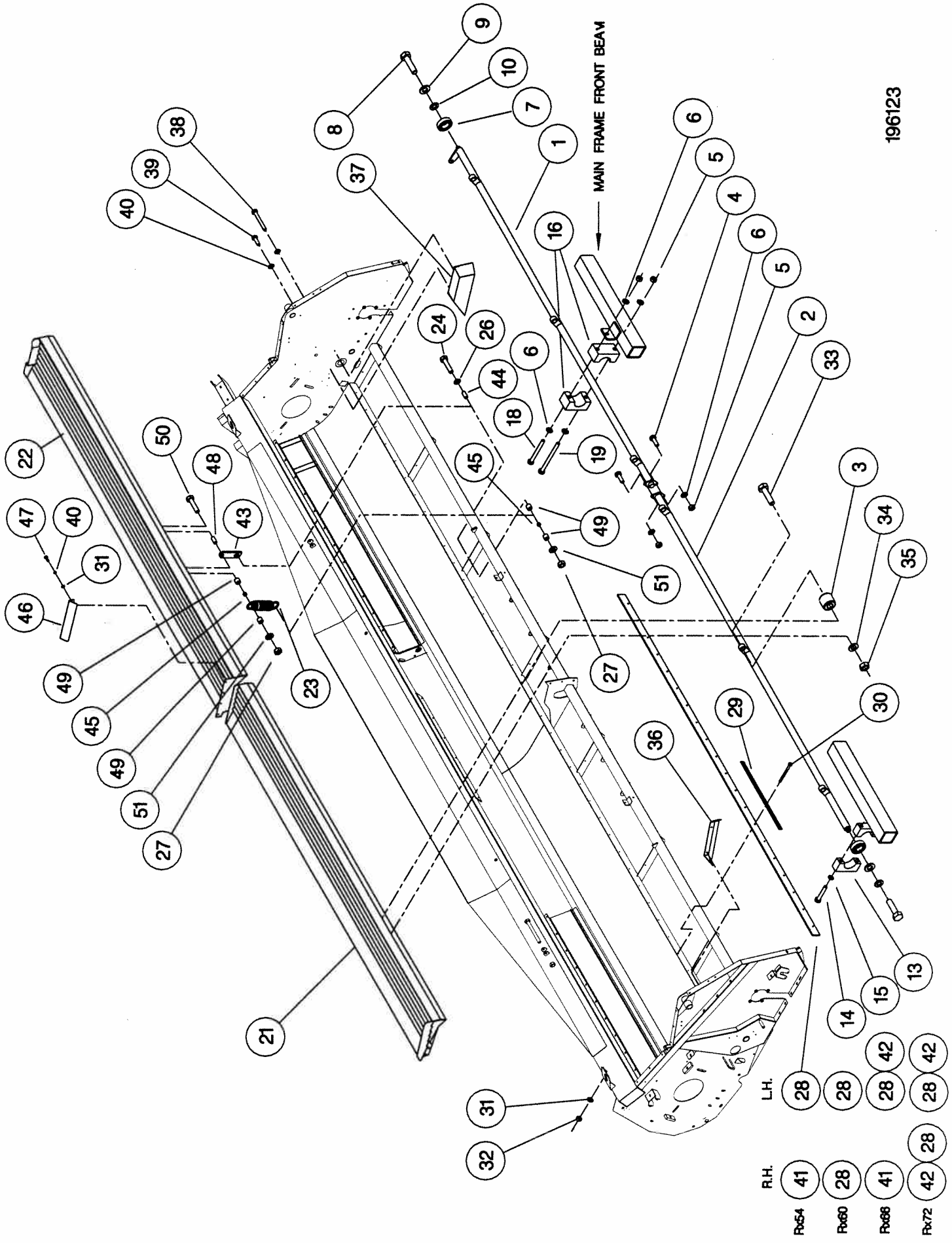

196123

**Shelbourne Reynolds Engineering Limited**

ASSY NUMBER: 196132 01		ASSY DESCRIPTION: SHORT DIVIDERS SUB (RX & CX)					
ITEM	PART NO	DESCRIPTION	QTY	ITEM	PART NO	DESCRIPTION	QTY
1	193348 01	SHORT DIVIDER LH	1				
2	193348 02	SHORT DIVIDER RH	1				

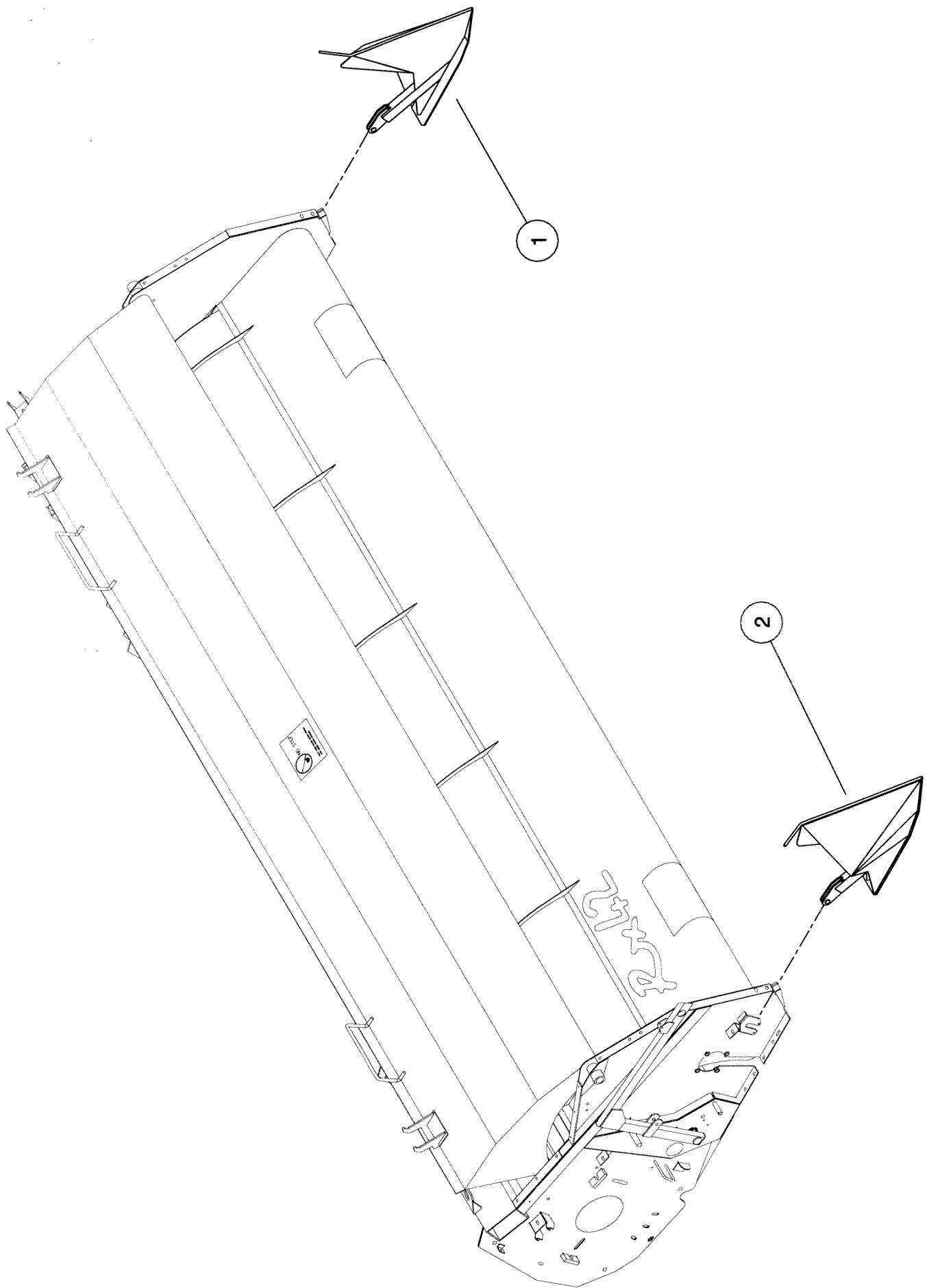

196132

**Shelbourne Reynolds Engineering Limited**

ASSY NUMBER: 196140 12		ASSY DESCRIPTION: HYDRAULIC CIRCUIT SUB 7.2M					
ITEM	PART NO	DESCRIPTION	QTY	ITEM	PART NO	DESCRIPTION	QTY
1	REF	HYDRAULIC RAM	2				
2	HHBC34610	HYDRAULIC HOSE LH	1				
3	HHBC59610	HYDRAULIC HOSE RH	1				
4	HPPD07100	HYD.TEE FITTING	1				
5	FIT-0213	HYD.BULKHEAD FITT.	1				
6	CLP-01012	P CLIP	6				
7	SCW-5180	SELF TAP SCREW	4				
9	HSS-0086	SETSCREW	2				
10	WSH-0009	PLAIN WASHER	2				
11	NUT-0260	NYLOC NUT	2				

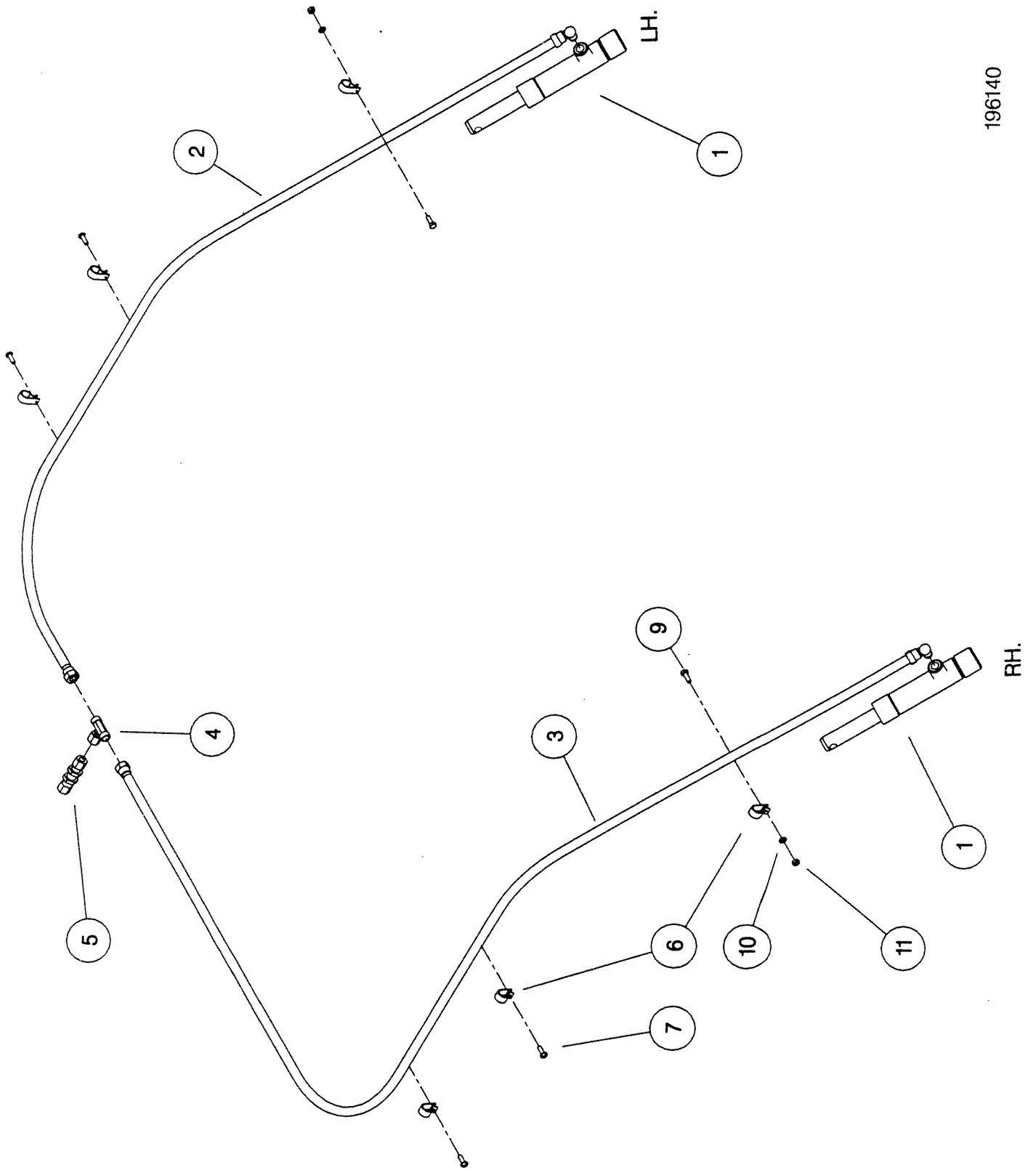

196140

**Shelbourne Reynolds Engineering Limited**

ASSY NUMBER:		ASSY DESCRIPTION:HARD FLIGHT AUGER ASSY 7.2M							
196141 32	196141 32	ITEM	PART NO	DESCRIPTION	QTY	ITEM	PART NO	DESCRIPTION	QTY
1	194355 01			HARD FLIGHT AUGER W. ASSY.	1	27	AUG-03000	HAIRPIN COTTER	16
2	192011 01			AUGER DRIVE SHAFT	1	OR		(16 FINGERS OPTION)	20
3	HSSF12204			SET SCREW	4	OR		(20 FINGERS OPTION)	24
4				BEARING	1	OR	193203 01	COVER PLATE	3
5	BRG-2020			BEARING	3	28	WSH-0056	SPRING WASHER	18
6	BRG-0240			SET SCREW	12	29	190735 01	BLANKING PLATE	3
7	HSS-0191			PLAIN WASHER	16	30		(16 FINGERS OPTION)	18
8	WSH-0015			SPRING WASHER	12	OR		(20 FINGERS OPTION)	8
9	WSH-0061			NYLOC NUT	4	OR		(24 FINGERS OPTION)	4
10	NUT-0265			AUGER SHAFT	1	31	194363 01	AUGER FLIGHT EXTENSION LH	0
11	192363 03					32	194363 02	AUGER FLIGHT EXTENSION RH	1
12				UPPER FINGER PL		33	SCBA08172	BUT. SCKT HD SCREW	1
13	AUG-01000			(16 FINGERS OPTION)	16	34	WSH-0058	WASHER	8
OR	UP TO 2000			(20 FINGERS OPTION)	20	35	WSH-0012	WASHER	4
OR				(24 FINGERS OPTION)	24	36	NUT-0263	NUT (M8 NYLOC)	8
14	AUG-01500			LOWER FINGER PL	16	37	AUG-00500	AUGER FINGER GUIDE (2001 ON)	16
OR	UP TO 2000			(16 FINGERS OPTION)	20			(16 FINGERS OPTION)	20
OR				(20 FINGERS OPTION)	24			(20 FINGERS OPTION)	24
15	AUG-02000			FINGER GUIDE	16			(24 FINGERS OPTION)	16
OR	UP TO 2000			(16 FINGERS OPTION)	20			(24 FINGERS OPTION)	20
OR				(20 FINGERS OPTION)	24			(24 FINGERS OPTION)	24
16	SCW-4960			BUTT.HD.SKT.SCREW	48				48
17	WSH-0009			PLAIN WASHER	66				66
18	NUT-0260			NYLOC NUT	48				48
19	192368 01			AUGER CRANK	1				1
20	AUG-02500			FINGER HOLDER	24				24
21	SCW-4959			BUTT.HD.SKT.SCREW	18				18
22	192364 01			AUGER CLAMP	1				1
23	SCCA10412			CAP HD SKT SCREW	4				4
24									
25									
26	192310 02			FINGER (16mm DIA. RICE)	16				16
OR				(16 FINGERS OPTION)	20				20
OR				(20 FINGERS OPTION)	24				24
				(24 FINGERS OPTION)					

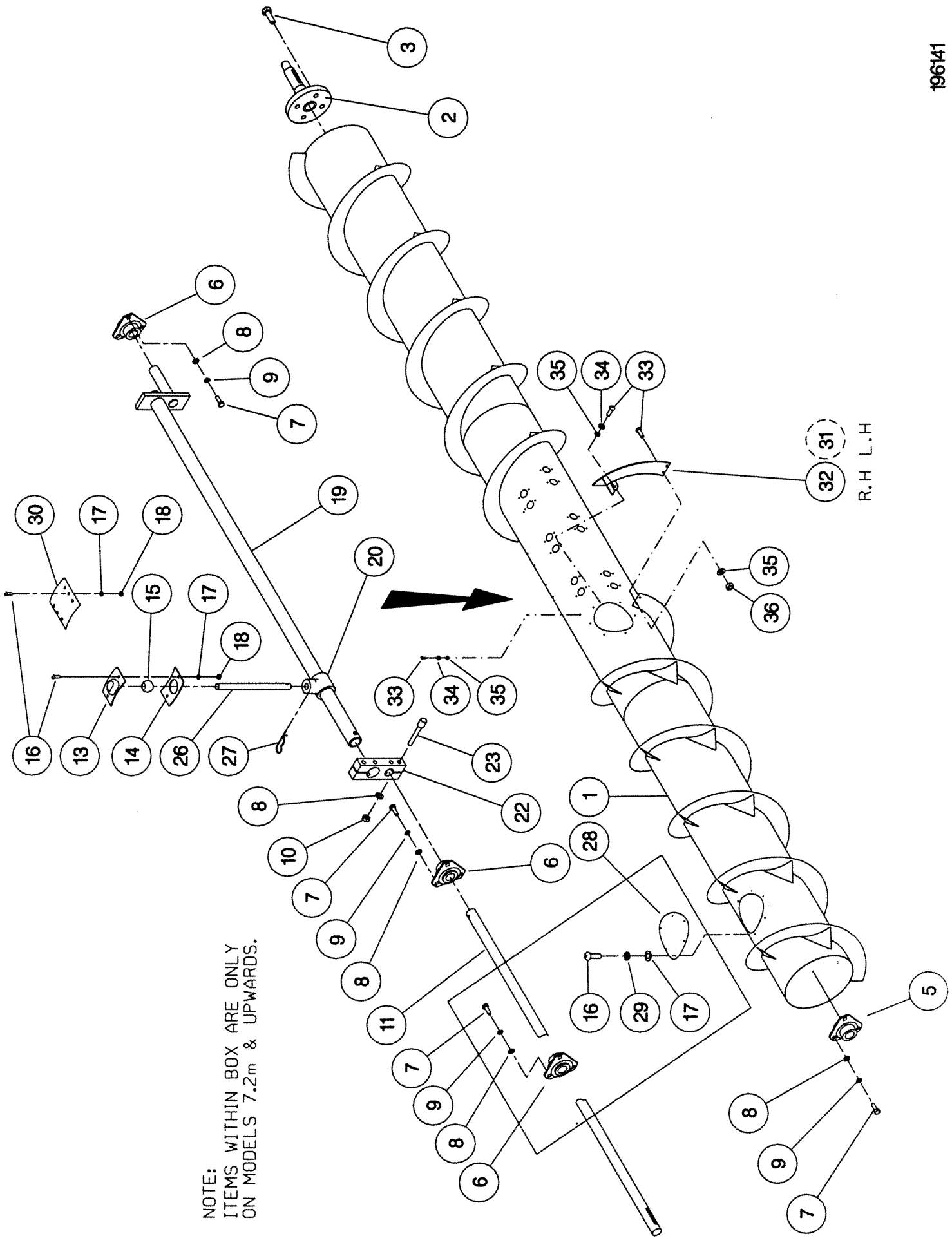

NOTE:  
 ITEMS WITHIN BOX ARE ONLY  
 ON MODELS 7.2m & UPWARDS.

R.H L.H

**Shelbourne Reynolds Engineering Limited**

ASSY NUMBER: 196143 12		ASSY DESCRIPTION: HEADER LIGHTS SUB 7.2M					
ITEM	PART NO	DESCRIPTION	QTY	ITEM	PART NO	DESCRIPTION	QTY
1	LMP-10501	INDICATOR LIGHT ASSY	2				
1a	BLB-0075	BULB	2				
2	ETM-00440	LOOP TERMINAL	2				
3	SCW-5180	SELF TAP SCREW	3				
4	ETM-00560	MALE BULLET TERM.	2				
5	193513 01	WIRE LOOM & PLUG ASSY	1				
6	CFC-00500	FIXING CLIP	6				
7	193567 01	INDICATOR GUARD	2				
8							
9							
10	193516 01	LOOM & PLUG ASSY (JD ONLY)	1				
11							
12							
13							
14							
15	TPE-00250	REFLECTIVE TAPE - AMBER	0.1				
15	TPE-00250	REFLECTIVE TAPE - AMBER	0.1				
16	TPE-00251	REFLECTIVE TAPE - RED	0.1				
16	TPE-00251	REFLECTIVE TAPE - RED	0.1				

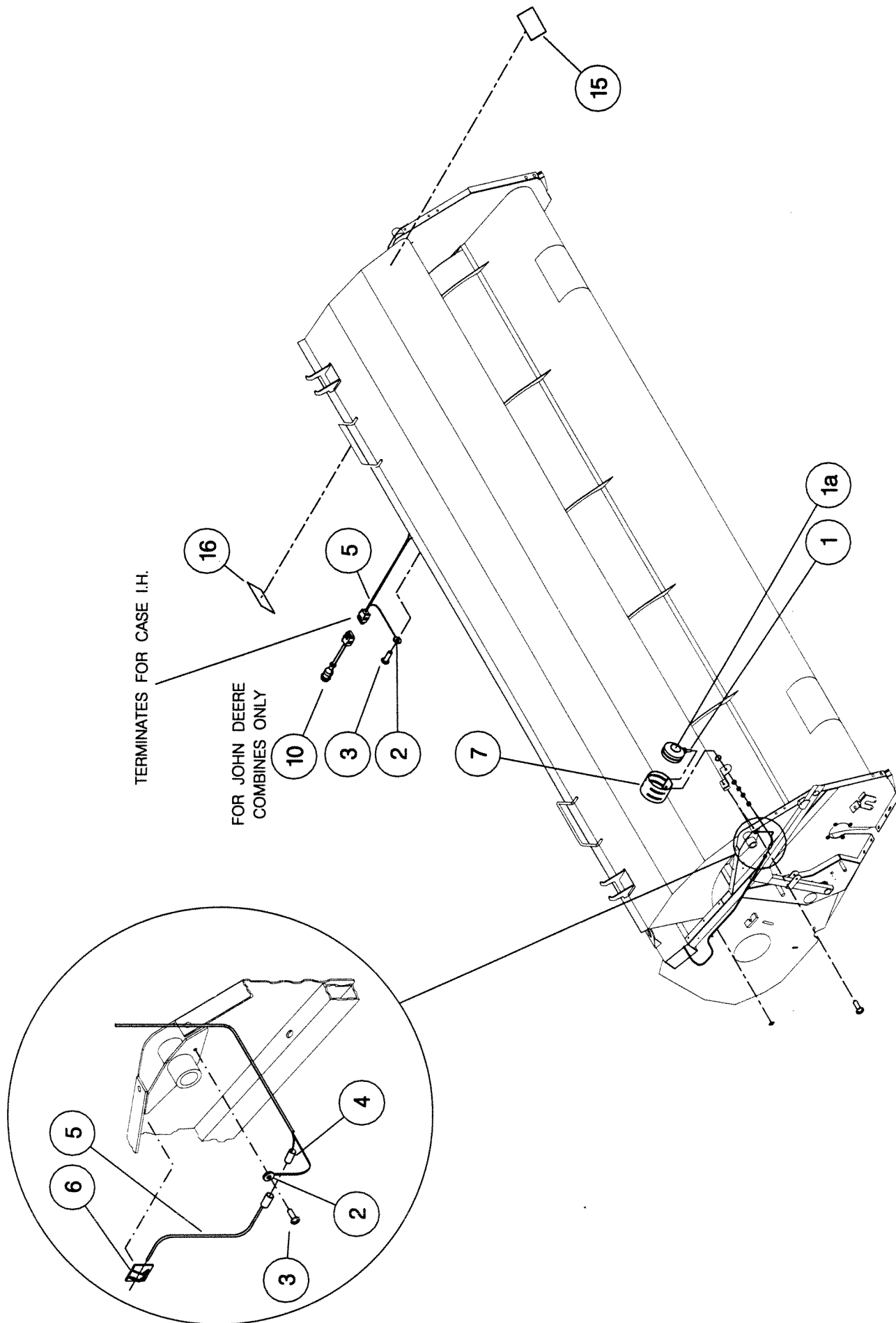

TERMINATES FOR CASE I.H.

FOR JOHN DEERE  
COMBINES ONLY

**Shelbourne Reynolds Engineering Limited**

ASSY NUMBER: 196144 01		ASSY DESCRIPTION: RX ROTOR MTG SUB (1998)					
ITEM	PART NO	DESCRIPTION	QTY	ITEM	PART NO	DESCRIPTION	QTY
1	193504 01	ROTOR MTG PLATE R.H	1				
2	193295 01	ROTOR MTG PLATE L.H	1				
3	BRG-3275	BEARING	3				
4	HSS-0235	SETSCREW	8				
5	WSH-0065	WASHER	8				
6	SCW-0515	SCREW	8				
7	WSH-0015	WASHER	20				
8	NUT-0265	NUT	14				
9	BLTA10520	BOLT	6				
10	193291 01	DIVISION PLATE	1				
11							
12	NUTA07120	AERO-TIGHT NUT	5				
13	HSS-0241	SETSCREW	9				
14							
15	WSH-0018	WASHER	4				
16	NUT-0269	NUT	4				
17	192502 01	VEE STRIP ASSY	1				
18	HSS-0140	BOLT	1				
19	NUT-0263	NYLOC NUT	1				
20	NUT-0164	NUT PLAIN	2				
21	193220 01	DIVIDING PLATE	2				
22	WSH-0012	WASHER	3				
23							
24	192876 01	SHIM (1mm THICK)					
25	192876 02	SHIM (2mm THICK)					

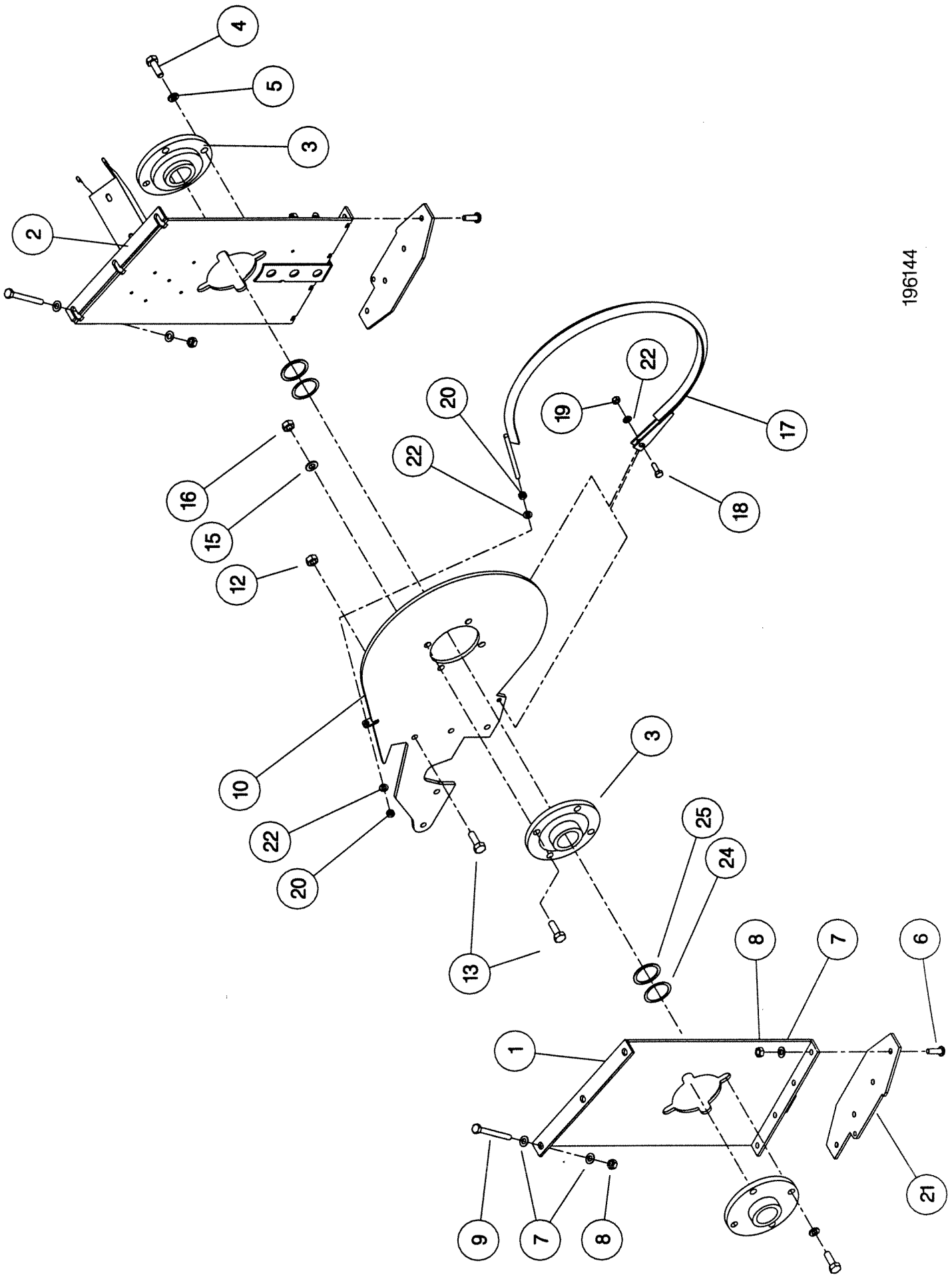

196144

**Shelbourne Reynolds Engineering Limited**

ASSY NUMBER: 196181 02		ASSY DESCRIPTION: ROTOR/AUGER DRIVE 1999 (RX72 & CX78)	
ITEM	PART NO	DESCRIPTION	QTY
1	191652 01	GEARBOX BRACKET	1
2	BSH-1530	BUSH	4
3	GEA-0095	BEVEL GEARBOX (SEE PARTS LIST GEA-0095)	1
4	HSSG12174	SET SCREW	4
5	WSH-0065	SPRING WASHER	10
6	WSH-0018	PLAIN WASHER	13
7	190119 04	PLAIN WASHER	4
8	BLTA12290	BOLT	4
9	PTO-09010	POWER SHAFT	1
9a	BLT-2158	SHEAR BOLT	
9b	NUT-0164	NUT	
10	GEA-0135	FIVE SPEED GEARBOX ASSY (SEE PARTS LIST GEA-0135)	1
11			
12	GEA-0102	DROPBOX ASSY (SEE PARTS LIST GEA-0102)	1
13	HSS-0238	SET SCREW	6
14	194061 01	DROP BOX SUPPORT PLATE	1
15	194068 01	SPACER PLATE	1
16	HSS-0241	SET SCREW	3
17	190119 22	WASHER	6
18			
19			
20			
21	131041 01	SPROCKET IDLER	2
22	BRG-1995	BEARING	2
23	CIR-0470	CIRCLIP	2
24	190060 06	IDLER SPINDLE	2
25	191040 01	IDLER SPACER	2
26	191777 01	IDLER ADJ SCREW	1
27	191774 01	PLATE	1
28	NUT-0269	NUT	4
		PTO GUARD KIT	1
		DROPBOX INPUT SHAFT KIT (RX72 & CX78 ONLY)	1

ON RX72, CX78 & CX84

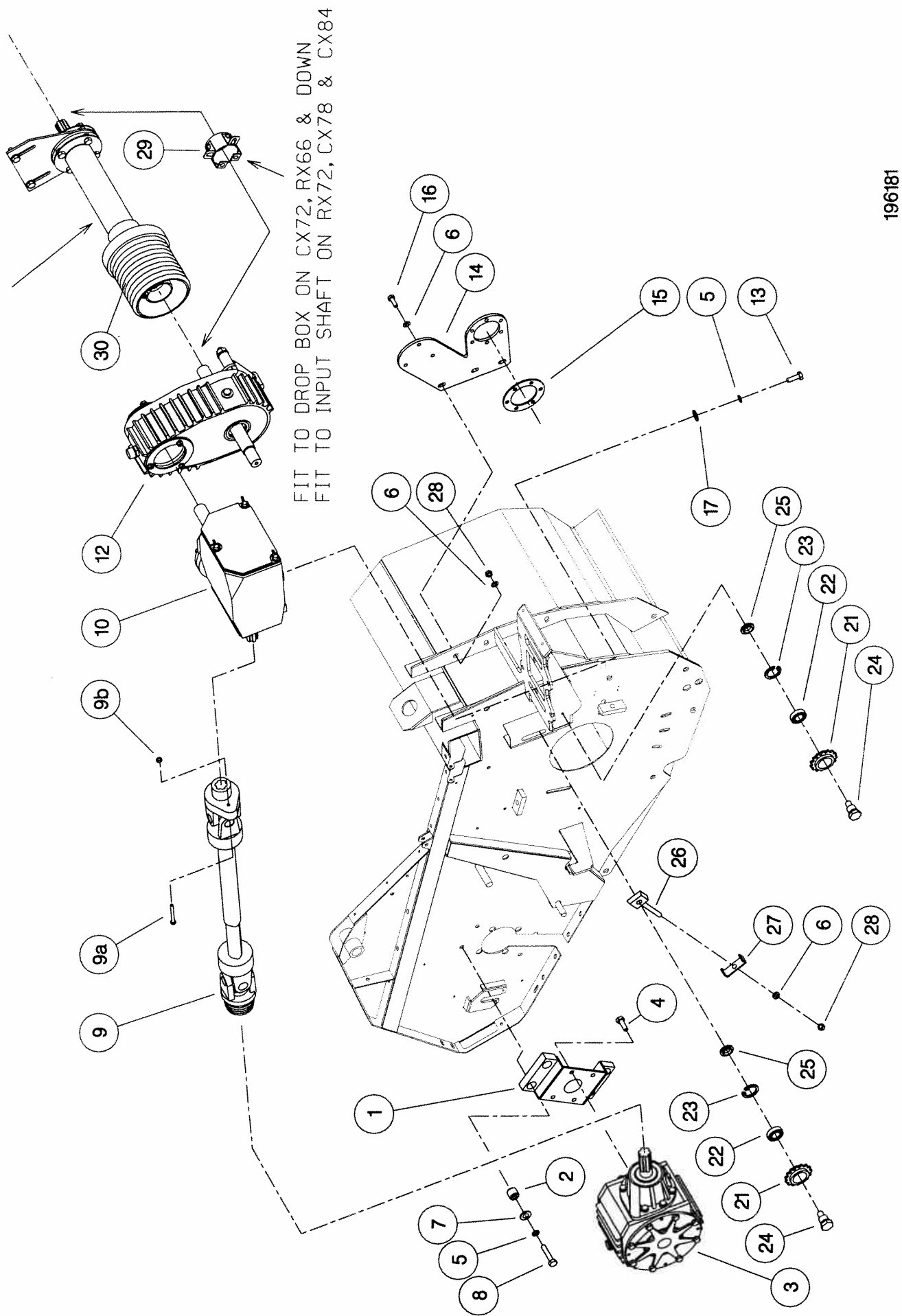

**Shelbourne Reynolds Engineering Limited**

ASSY NUMBER: 196183 01		ASSY DESCRIPTION: RX RS EMBLEMS AND GUARDS SUB (1999)					
ITEM	PART NO	DESCRIPTION	QTY	ITEM	PART NO	DESCRIPTION	QTY
1	193299 01	L.H.GUARD	1	39	NUT-0164	NUT	10
2	BLTA08470	BOLT	2	40	BLTA08350	SHEARBOLT	10
3	WSH-0012	PLAIN WASHER	14	41	EDS-11400	EDGING STRIP	2.0
4	NUT-0263	NYLOC NUT	10	42	WSH-0058	WASHER	4
5	LTC-00040	SLAM LATCH	1	43	HSS-0145	SET SCREW	1
6	194102 01	L.H. TOP COVER	1	44	193838 02	EMBLEM (RICE SPECIAL)	2
7	HSS-0140	SET SCREW	9	45	194103 01	EMBLEM (ROTOR SPEED RATIO'S)	1
8	192570 01	FRONT DEFLECTOR L.H.	1	46	196463 01	CANNISTER BRACKET	1
9	WSH-0009	PLAIN WASHER	8	47	WDA-00025	CANNISTER	1
10	WSH-0056	SPRING WASHER	6	48	HSS-0145	SET SCREW	2
11	NUT-0260	NYLOC NUT	3	49	CHN-0145	CHAIN	0.17
12	191355 01	COVER	1	50	RCL-0015	R-CLIP	1
13	HSS-0084	SET SCREW	10				
14	SCW-4700	WING SCREW	1				
15	193478 01	R.H.GUARD	1				
16	192555 01	REAR DRIVE GUARD(5th POS.)	1				
17							
18	WSH-1038	PENNY WASHER	3				
19	191359 01	IDENTIFICATION PLATE	1				
20	POP-0006	POP RIVET	4				
21	191983 01	EMBLEM (STRIPES & REYNOLDS)	2				
22	191982 01	EMBLEM (SHELBOURNE)	2				
23	610257 01	EMBLEM (READ MANUAL)	1				
24	127075 12	EMBLEM (GREASE 10 HOURS)	2				
25	193388 01	EMBLEM (FLYING OBJECTS)	2				
26	193389 01	EMBLEM (KEEP AWAY)	2				
27	193395 01	EMBLEM (TENSILOCK)	4				
28	190702 04	EMBLEM (SLING POINT)	4				
29	192839 01	EMBLEM (SHEARBOLT PART No.)	1				
30	610250 01	EMBLEM (SAFETY MAINTENANCE)	1				
31	192953 01	EMBLEM (1/4 TURN)	1				
32	193392 01	EMBLEM (STOP ENG BEFORE...)	1				
33	193393 01	EMBLEM (STOP ENG BEFORE...)	1				
34	193390 01	EMBLEM (DONT HANG CHAIN)	1				
35	193391 01	EMBLEM (PTO GUARD)	1				
36	193394 01	EMBLEM (ENGAGE STRIP ROTOR)	1				
37	193387 01	EMBLEM (AUGER/ROTOR SPEED)	1				
38	127075 16	EMBLEM (GREASE 50 HOURS)	7				

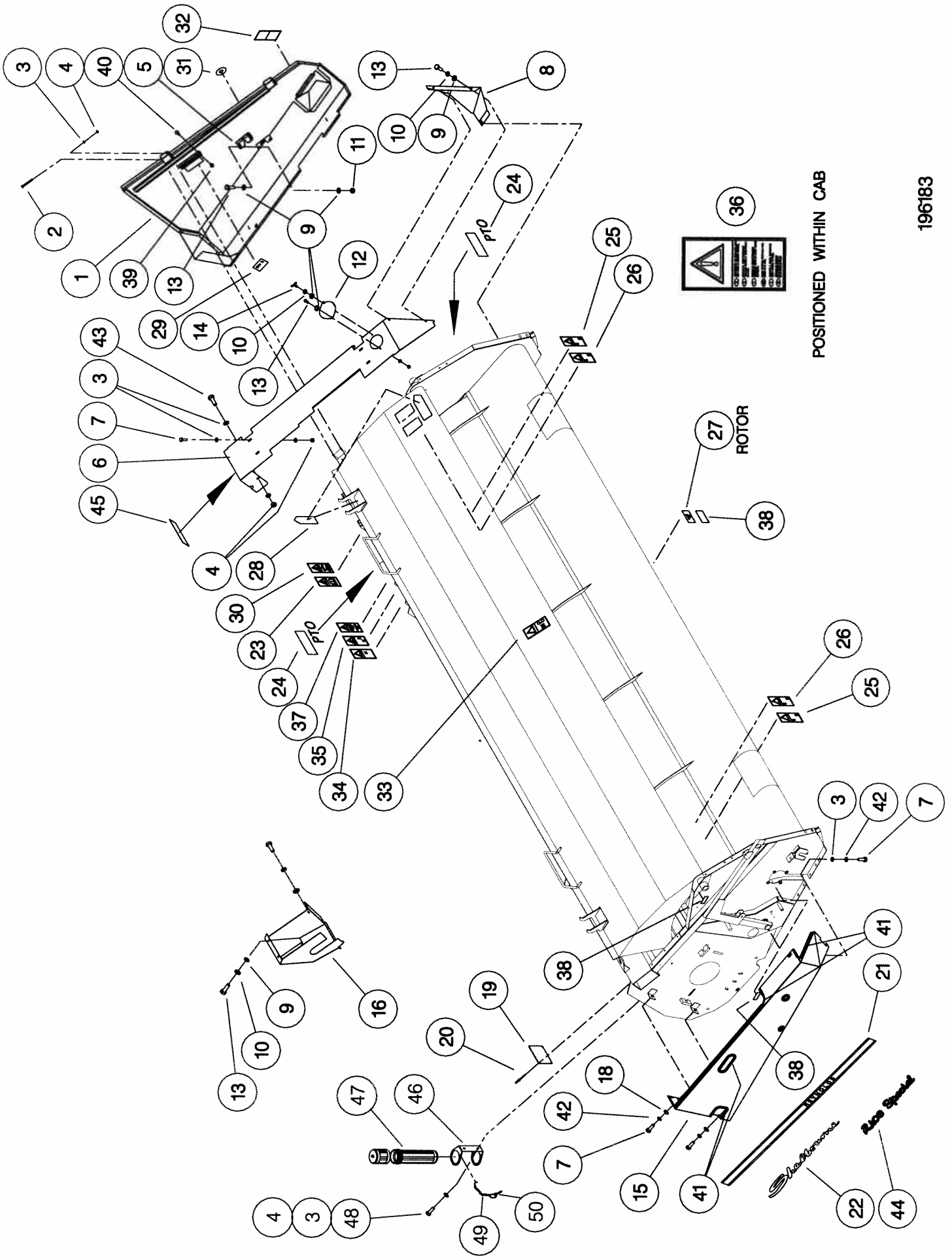

196183

**Shelbourne Reynolds Engineering Limited**

ASSY NUMBER: 196186 12		ASSY DESCRIPTION: FRAME & PARTS SUB (RX72-1999)					
ITEM	PART NO	DESCRIPTION	QTY	ITEM	PART NO	DESCRIPTION	QTY
1	194095 01	RX72 MAIN FRAME ASSY	1	38	HSS-0092	SETSCREW	1
2	192073 10	STRIPPER PLATE	2	39	WSH-0009	PLAIN WASHER	7
3	BLT-4710	COACH BOLT	36	40	NUT-0260	NYLOC NUT	7
4	NUT-0263	NUT	72	41	193480 01	SUPPORT BRACKET	1
5	WSH-0012	WASHER	72	42	192543 01	CROP DIVIDER ADJ.PLATE	2
6	191340 01	RUBBER SEAL	1	43	PIN-01790	LYNCH PIN & CHAIN	2
7	191339 01	CLAMP STRIP	2	44	193221 01	HEADER STAND BRACKET	1
8	POP-0006	POP RIVET	22	45	193222 01	HEADER FRONT STAND	2
9	193219 01	SKID	2	46	192550 01	NOSE ARM STOP PLATE	1
10	HSS-0316	SET SCREW	12	47			
11	WSH-0024	WASHER	6	48	193828 01	SKID ADJUSTER PLATE L.H	2
12	WSH-0070	WASHER	12	49	193828 02	SKID ADJUSTER PLATE R.H	2
13	NUT-0260	NUT	6	50	190119 07	WASHER	4
14				51	193480 02	SUPPORT BRACKET LH	1
15	NUT-0269	NUT	4	52	193231 01	RUBBER SEAL	2
16	WSH-0018	WASHER	4	53	193229 01	SEAL CLAMP	2
17	191259 02	ADJ COWL SUPPORT ARM R.H	1	54	193230 01	SEAL CLAMP	2
18	191259 01	ADJ COWL SUPPORT ARM L.H	1	55	SCW-4960	BUTT.HD.SKT.SCREW	12
19	BSH-3030	BUSH	2	56	WSH-0056	SPRING WASHER	12
20	BSH-3070	BUSH	4	57	193244 01	RETAINING NUT	2
21	NIP-0001	GREASE ZERK	2	58	193248 01	RETAINING SCREW	2
22	WSH-1547	WASHER	2	59	BLTA12380	BOLT	2
23	CIR-1150	CIRCLIP	2	60	193251 01	RETAINING BAR	2
24	193506 01	HYDRAULIC RAM	2	61	NUT-0170	PLAIN NUT	2
24a	RMSK00030	SEAL KIT	4	62	193363 01	ROTOR DEFLECTOR	2
25	HSS-0260	SET SCREW	4	63	HSS-0084	SETSCREW	6
26	PIN-1150	SPLIT PIN	2	64	193431 01	SKID WEAR PLATE	2
27	192193 01	ADJ COWL STOP L.H	1	65	193429 01	SKID WEAR CLAMP STRIP	2
28	192193 02	ADJ COWL STOP R.H	1	66	BLT-2700	COACH BOLT	16
29	HSS-0194	SET SCREW	7	67	SCW-1740	CSK.SOC.HEAD SCREW	8
30	WSH-0015	WASHER	17	68	194101 01	BELLY PAN WELD ASSY	2
31	NUT-0265	NUT	7	69			
32	192055 01	RUNNER ASSY L.H	1	70	HSS-0191	SETSCREW	12
33	192055 02	RUNNER ASSY R.H	1	71	WSH-0061	SPRING WASHER	12
34	SCW-1735	SCREW	6	72	194117 01	SKID WEAR CLAMP STRIP (REAR)	2
35	192304 01	AUGER END DEFLECTOR	2	73	190119 11	WASHER	6
36	HSS-0140	SET SCREW	6				
37	192494 01	INDICATOR ROD	1				

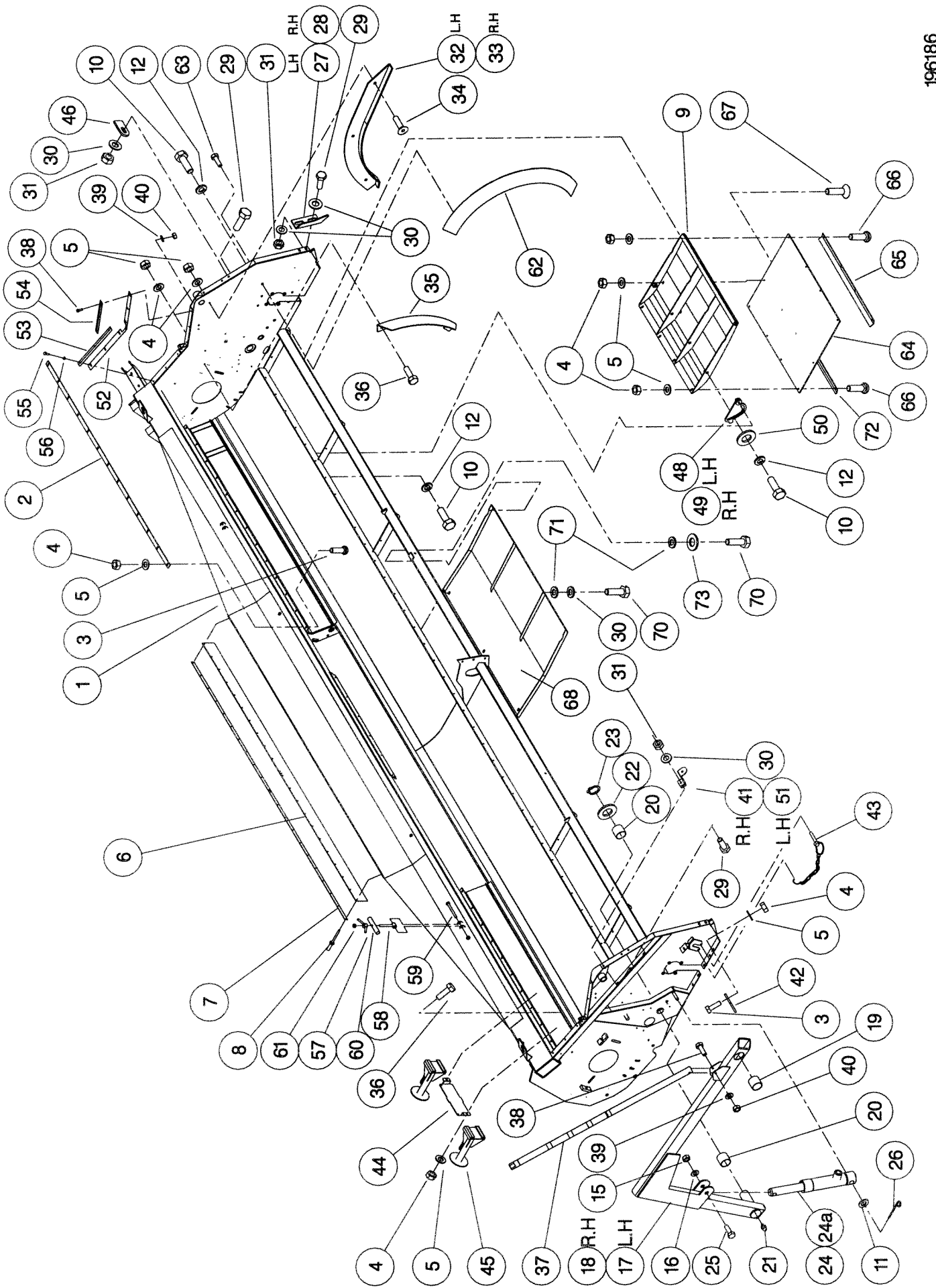

**Shelbourne Reynolds Engineering Limited**

ASSY NUMBER: GEA-0095		ASSY DESCRIPTION: BEVEL GEARBOX (1.5:1)					
ITEM	PART NO	DESCRIPTION	QTY	ITEM	PART NO	DESCRIPTION	QTY
1	191715 01	GEARBOX CASING	1				
2	191716 01	INPUT HOUSING	1				
3	191717 01	OUTSIDE END COVER	1				
4	191718 01	INSIDE END COVER	1				
5	191819 01	INPUT SHAFT (28T INVOLUTE)	1				
6	191798 01	BEVEL GEAR 20T (28T INV)	1				
7	191799 01	BEVEL GEAR 30T (25T INV)	1				
8	191800 01	OUTPUT SHAFT (25T INVOLUTE)	1				
9	BRG-7000	BEARING (TAPER 32210)	1				
10	BRG-7020	BEARING (TAPER 32211)	2				
11							
12	BRG-7040	BEARING	1				
13	SEA-0590	ROTARY SHAFT SEAL	1				
14	SEA-0600	ROTARY SHAFT SEAL	1				
15	191812	SHIM PACK (INPUT)	1				
16	191813	SHIM PACK (ENDS)	2				
17							
18	191735 01	SHAFT PLUG	1				
19	NUT-3010	LOCK RING	1				
20	WSH-6010	LOCK WASHER	1				
21							
22	WSH-1301	SHAKEPROOF WASHER	7				
23	HSS-0191	SET SCREW	16				
24							
25	SCW-0139	CAP HEAD SCREW	5				
26	WSH-0058	SPRING WASHER	5				
27	FIT-0254	BREATHER/DIP STICK	1				
28	FIT-0253	MAGNETIC DRAIN PLUG	1				
29							
30	FIT-0223	TAPER PLUG	1				
31	WSH-0061	SPRING WASHER	16				
32	SCW-0190	CAP SOC.HEAD SCREW	7				

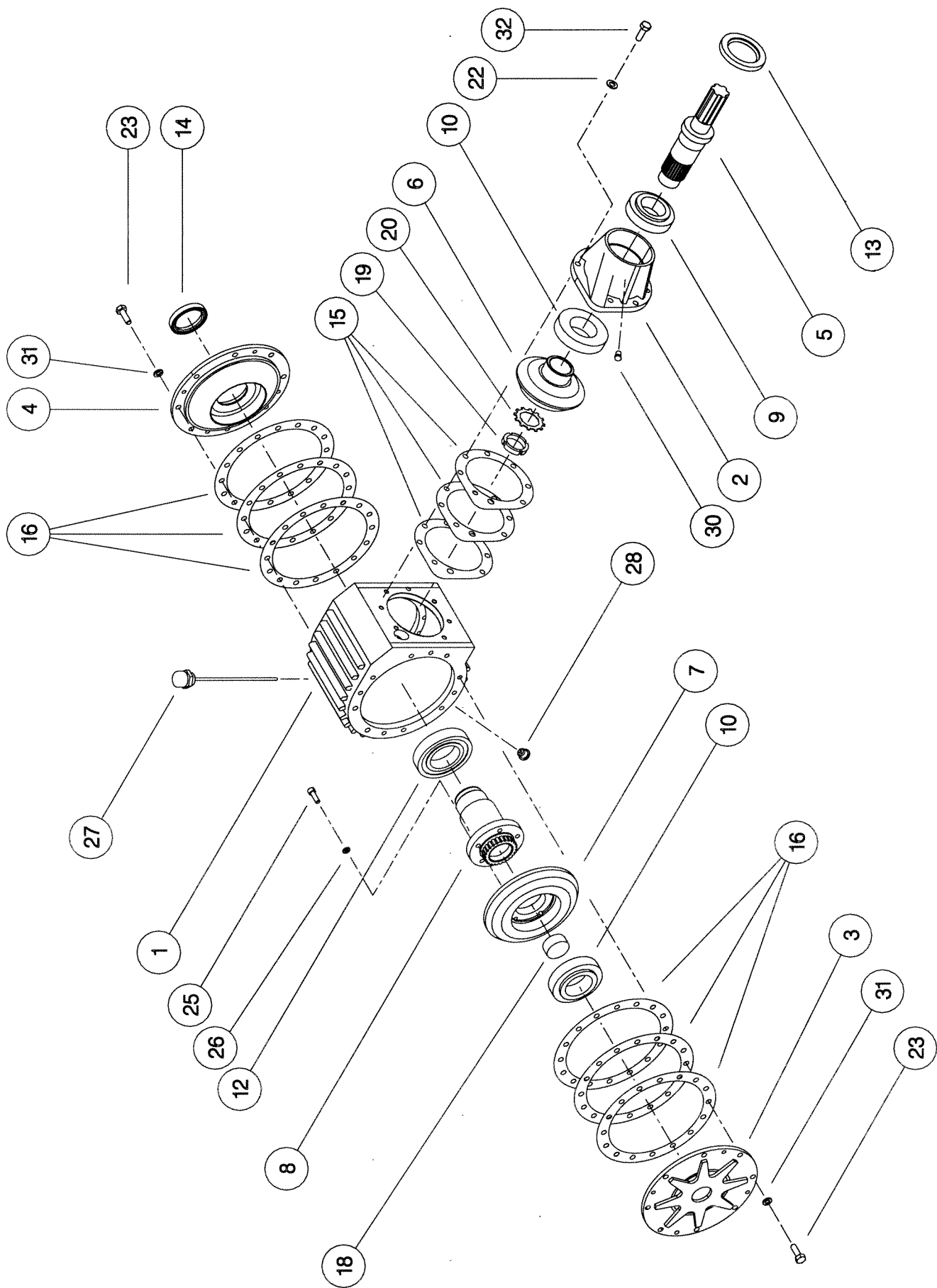

GEA-0095

**Shelbourne Reynolds Engineering Limited**

ASSY NUMBER: GEA-0102		ASSY DESCRIPTION: SHORT DROPBOX FOR RX & CX (1999)					
ITEM	PART NO	DESCRIPTION	QTY	ITEM	PART NO	DESCRIPTION	QTY
1	191723 01	GEARCASE	1	38	WSH-0012	PLAIN WASHER	5
2	191723 02	LID	1	39	191759 01	SEAL	1
3	191696 02	OUTPUT END CAP	1	40	191765 01	DOWL	2
4				41	NUT-0012	PHILLIDAS NUT	5
5				42	CIR-4000	SNAP RING CIRCLIP	1
6	191807 01	INPUT/AUGER OUTPUT SHAFT (28T INVOLUTE)	1	43	191928 01	IDENTIFICATION TAG	1
7	191801 01	INTERMED. SHAFT (28T INV)	1	44			
8	*	CHANGE GEAR (SEE DRIVE SUB)		45			
9	*	CHANGE GEAR (SEE DRIVE SUB)		46			
10	191803 01	SPUR GEAR 30T (28T INV)	1	48			
11	191884 01	SPUR GEAR 20T (28T INV)	1	49	191692 01	SPACER	2
12	NUT-3000	LOCK RING	1	50	191692 02	SHIM	7
13	WSH-6000	LOCK WASHER	1	51	HSSF10174	SET SCREW	1
14	191725 01	SPACER	1	52	190548 01	PLAIN WASHER	1
15	191894 01	SPACER	1	53	K1008045	KEY	1
16	BRG-6600	BEARING	1	54	*	AUGER SPROCKET (SEE DRIVE SUB)	
17	BRG-5800	BEARING	4				
18	SEA-0610	ROTARY SHAFT SEAL	2				
19	191756 01	GASKET	1				
20	191757	SEAL PACK	1				
21							
22	FIT-0255	BREATHER	1				
23	FIT-0253	MAGNETIC DRAIN PLUG1					
24	FITD00005	SIGHT GLASS/SEAL	1				
25	SCW-0196	CAP HEAD SCREW	12				
26	WSH-1301	SHAKEPROOF WASHER	15				
27	HSS-0202	SETScrew	6				
28							
29	BLTA10290	BOLT	3				
30	SCW-0190	CAP HEAD SCREW	3				
31	WSH-0015	PLAIN WASHER	3				
32	HSS-0188	SET SCREW	1				
33							
34							
35	WSH-0061	SPRING WASHER	10				
36							
37	191737 01	STUD	5				



**Shelbourne Reynolds Engineering Limited**

ASSY NUMBER: GEA-0135		ASSY DESCRIPTION: 5 SPEED G.BOX ASSY ALUM/FINNEED 1997 (WITH DROP BOX)					
ITEM	PART NO	DESCRIPTION	QTY	ITEM	PART NO	DESCRIPTION	QTY
1	191821 01	GEARBOX CASING	1				
2	191829 01	INPUT SHAFT	1				
3	191825 01	SEAL HOUSING	1				
4	SEA-0550	ROTARY SHAFT SEAL	1				
5	BRG-6600	BEARING	1				
6	BRG-6601	BEARING	2				
7	CIR-3800	CIRCLIP	3				
8	CIR-2700	CIRCLIP	3				
9	191828 01	LAYSHAFT	1				
10	191823 01	BEVEL GEAR (15T)	1				
11	BRG-6800	BEARING	1				
12							
13	HSS-0194	SET SCREW	14				
14	WSH-0061	SPRING WASHER	14				
15	192924 01	REMOVABLE COVER	1				
16	ORA260000	'O' RING SEAL STRIP	0.7				
17	SCW-4760	WING SCREW	3				
18	WSH-1301	SHAKEPROOF WASHER	3				
19	FIT-0223	PLUG	1				
20	FIT-0218	BREATHER	1				
21							
22	191822 18	CHANGE GEAR (18T)	1				
23	191822 20	CHANGE GEAR (20T)	1				
24	191822 22	CHANGE GEAR (22T)	1				
25	191822 24	CHANGE GEAR (24T)	1				
26	191822 26	CHANGE GEAR (26T)	1				
27	191822 28	CHANGE GEAR (28T)	1				
28	191691 02	OUTPUT HOUSING (HOLES, 1997)	1				
29	191885 01	OUTPUT SHAFT	1				
30	191824 01	BEVEL GEAR (18T)	1				
31	BRG-6000	BEARING	1				
32	BRG-5700	BEARING	1				
33	SEA-0565	ROTARY SHAFT SEAL	1				
34	191843 01	SLOTTED NUT	1				
35	PIN-1168	SPLIT PIN	1				
36	191830	GASKET SET	1				
37	191831	GASKET SET	1				

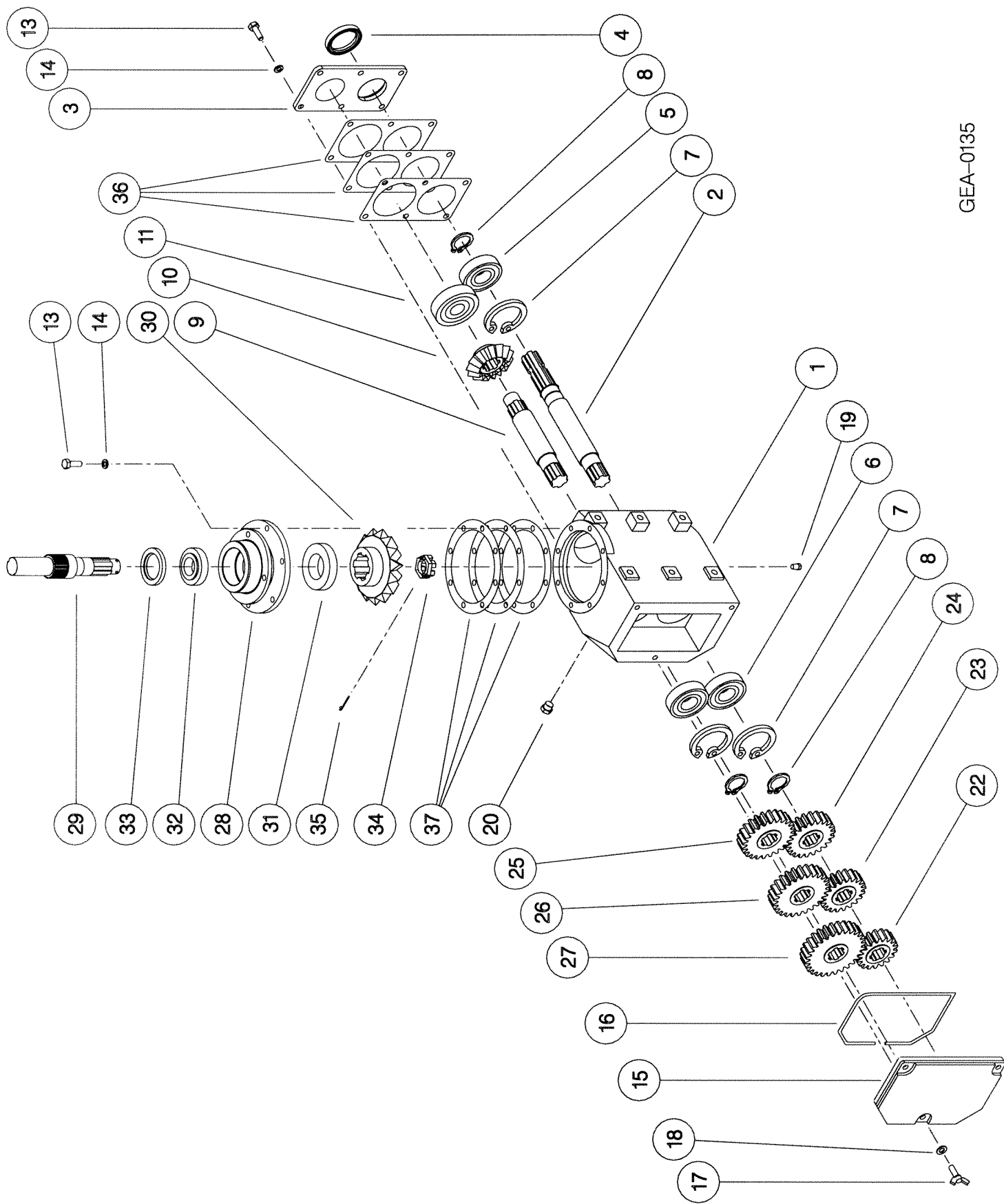

GEA-0135

**Shelbourne Reynolds Engineering Limited**

KIT-00115		ASSY DESCRIPTION:		AUGER DRIVE SPROCKET/CLUTCH ASSY			
ASSY NUMBER:	PART NO	DESCRIPTION	QTY	ITEM	PART NO	DESCRIPTION	QTY
1	192763 01	SPROCKET ASSY 50T	1				
2	BSH-3019	BUSH	1				
3	192008 01	THRUST WASHER	1				
4	192013 01	CLUTCH HUB	1				
5	131005	CLUTCH PLATE	2				
6	192014 01	DRIVE DISC	1				
7	131073 04	SPACER (1999 ONWARDS-62mm)	6				
OR	131073 03	SPACER (PRE 1999-67mm)	6				
8	131063	SPRING	6				
9	192009 01	FIXING RING	1				
10	BLTF12570	COACH BOLT	6				
11	WSH-0018	PLAIN WASHER	6				
12	NUT-0170	PLAIN NUT	12				
13	192254 01	SPROCKET 50T	1				
14	192253 02	SPACER	4				
15	190119 11	WASHER	8				
16	BLTA10440	BOLT	4				
17	NUT-0265	NYLOC NUT	4				

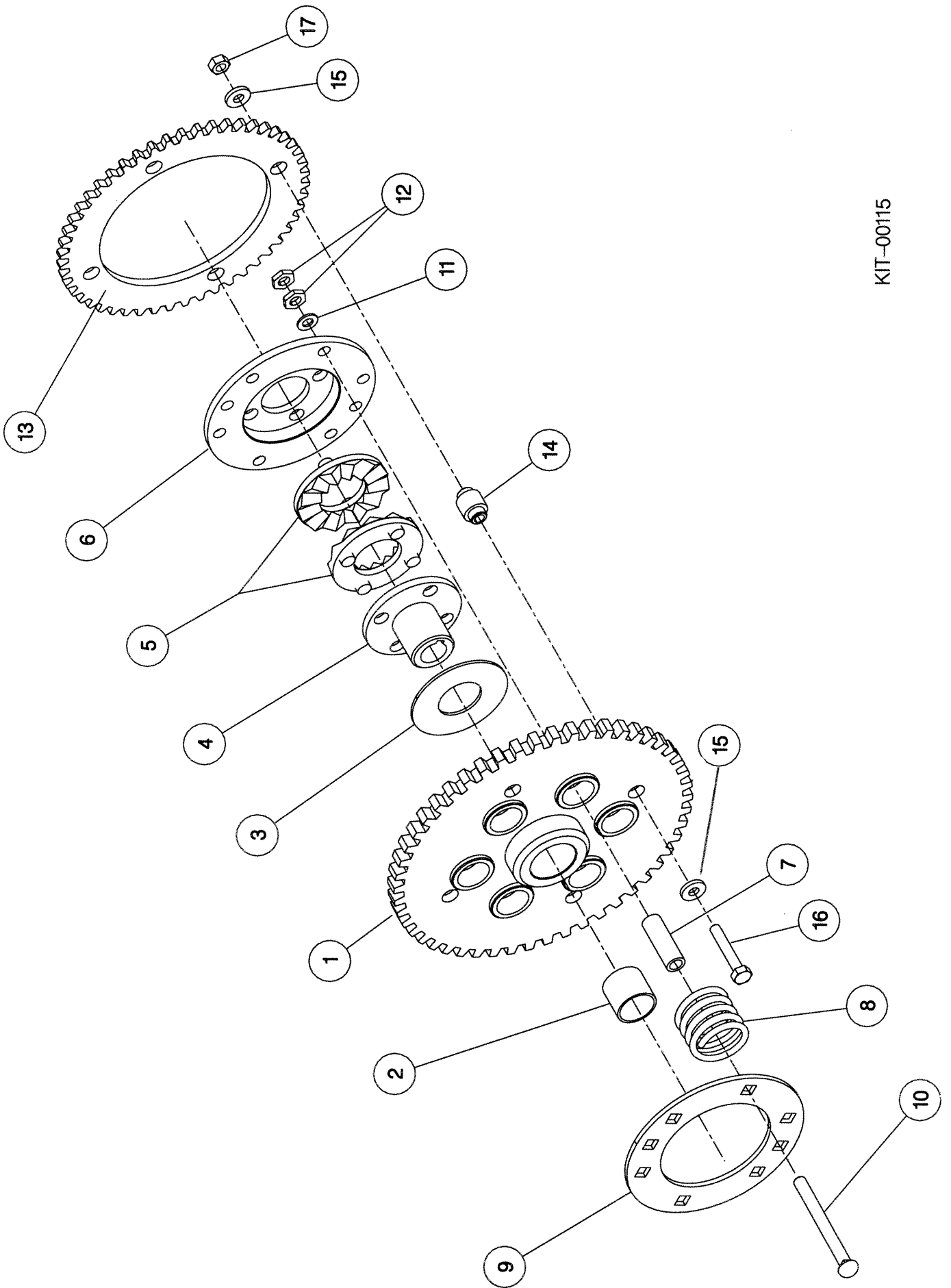

KIT-00115

**Shelbourne Reynolds Engineering Limited**

KIT-00424		ASSY DESCRIPTION: GEARBOX INPUT SHAFT SUB					
ASSY NUMBER:							
ITEM	PART NO	DESCRIPTION	QTY	ITEM	PART NO	DESCRIPTION	QTY
1	192985 06	GUARD TUBE	1				
2	192992 01	GUARD SECURING BRACKET	2				
3	SCW-5104	SELF TAP SCREW	2				
4	WSH-0015	PLAIN WASHER	2				
5	PTO-24000	PTO COUPLING1					
6	192982 07	INPUT SHAFT	1				
7	PTO-00123	PTO GUARD CONE	1				
8							
9	SCW-5180	SELF TAP SCREW	3				
10	HSS-0275	SET SCREW	4				
11	192991 01	GUARD SUPPORT PLATE	1				
12	NUT-0170	NUT	8				
13	BRG-24500	BEARING	1				
14	192993 01	SUPPORT PLATE	1				
15	WSH-0018	WASHER	12				
16	NUT-0269	NUT	6				
17	HSS-0238	SETSCREW	2				
18	194098 01	GUARD BRACKET	1				

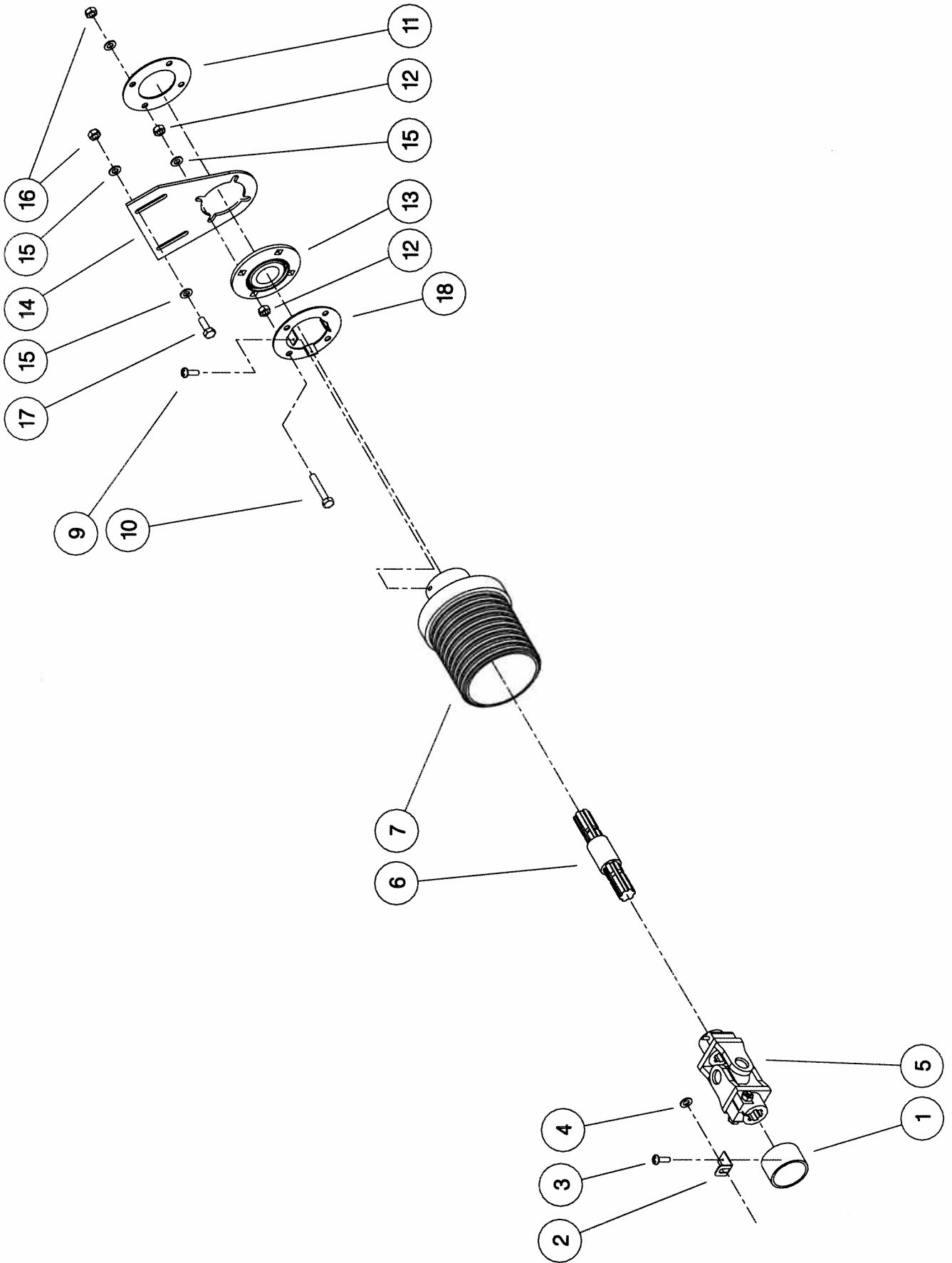

KIT-00424

**Shelbourne Reynolds Engineering Limited**

KIT-00525		ASSY DESCRIPTION: PTO END GUARD					
ASSY NUMBER:	KIT-00525	ASSY DESCRIPTION: PTO END GUARD					
ITEM	PART NO	DESCRIPTION	QTY	ITEM	PART NO	DESCRIPTION	QTY
1	192985 06	GUARD TUBE	1				
2	192992 01	GUARD SECURING BRACKET	2				
3	SCW-5104	SCREW	2				
4	WSH-0015	WASHER	2				
5	191763 01	PTO BRACKET	2				

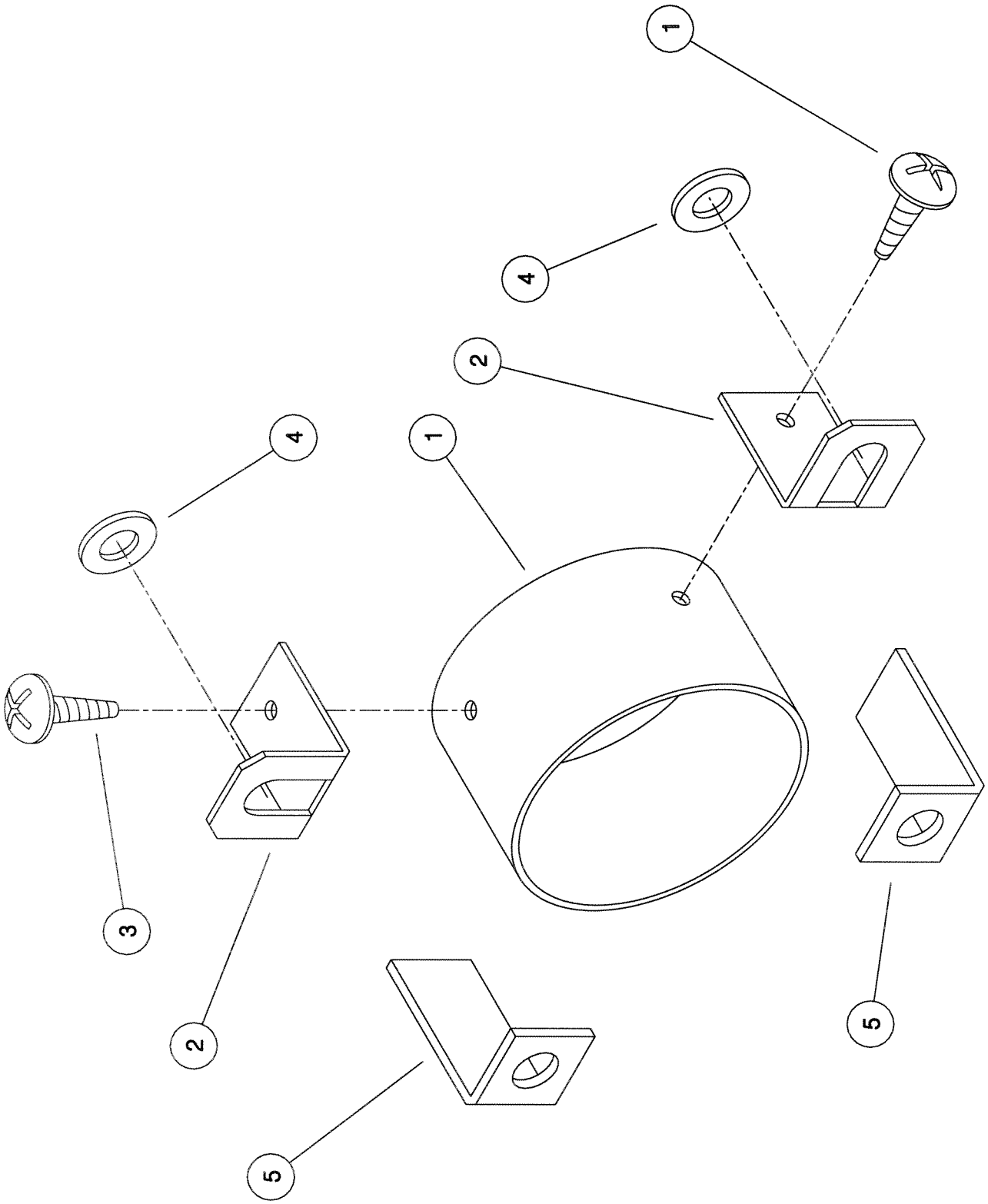

KIT-00525

**Shelbourne Reynolds Engineering Limited**

ASSY NUMBER: KIT-00976		SUB ASSY DESCRIPTION: BALL JOINT COUPLING (CAST ROTOR)					
ITEM	PART NO	DESCRIPTION	QTY	ITEM	PART NO	DESCRIPTION	QTY
1	193114 01	SPLINED BALL	1				
2	SCW-4530	GRUB SCREW	1				
3							
4	193106 01	DRIVE RING PLATE	1				
5	HSS-0198	SETSCREW	6				
6	WSH-0015	WASHER	6				
7	NUT-0265	NUT	6				
8	193077 01	GREASE TUBE	1				
9	193078 01	GREASE TUBE ADAPTOR	1				
10	NIP-00600	GREASE NIPPLE	1				

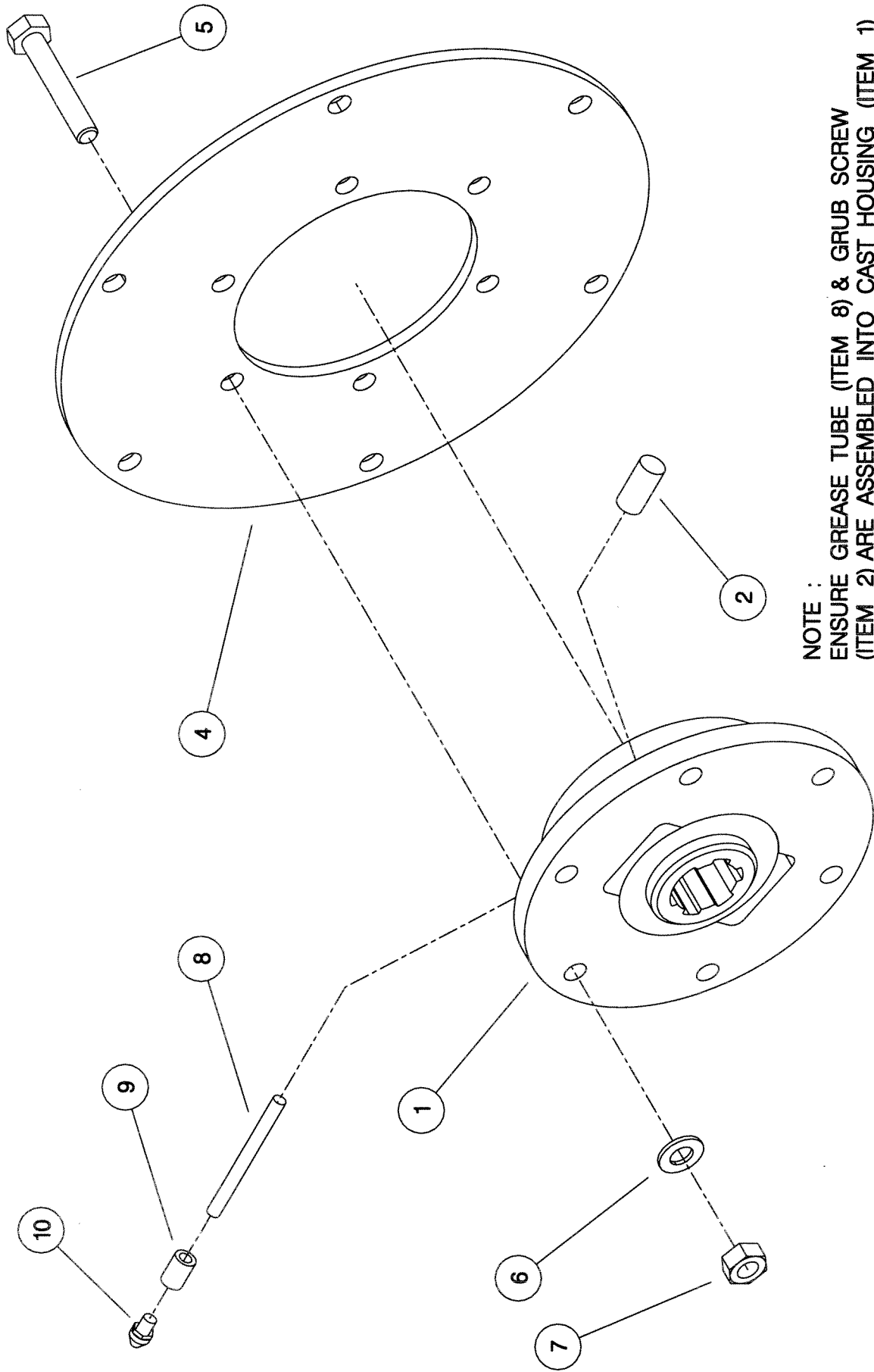

NOTE :  
 ENSURE GREASE TUBE (ITEM 8) & GRUB SCREW  
 (ITEM 2) ARE ASSEMBLED INTO CAST HOUSING (ITEM 1)  
 THE ORIENTATION SHOWN IS FOR A R.H. ROTOR  
 OPPOSITE ORIENTATION FOR L.H. ROTOR.

**Shelbourne Reynolds Engineering Limited**

ASSY NUMBER:		RDS-0001/RDS-0005			ASSY DESCRIPTION: TACHO KIT		
ITEM	PART NO	DESCRIPTION	QTY	ITEM	PART NO	DESCRIPTION	QTY
1	RDS-0010	TACHO HEAD COMPLETE	1	13	RDS-0020	MAGNET CARRIER ,	1
2	RDS-0011	TACHO HEAD PLUG & ARMS	1			SET SCREW ,	1
3	RDS-0012	HARTING CONNECTOR & STICKER	1			PENNY WASHER & SPRING WASHER	1
4	RDS-0013	AUDIBLE ALARM, FIXING BRACKET & SELF TAP.SCREWS	1	14	RDS-0021	ROTOR SENSOR BRACKET	1
5	RDS-0014	POWER CONNECTION LEAD	1				
6	FUS-0022	FUSE	1				
7	RDS-0015	COMBINE LEAD	1				
8	RDS-0016	24V-12V CONVERTER KIT (NOT INCLUDED IN RDS-0001)	1				
9							
10	RDS-0017	HEADER LEAD	1				
11	RDS-0018	SHAFT SENSOR	2				
12	RDS-0019	MAGNET , TAPTITE BOLT & FIBRE WASHER	1				

HEADER KIT. PART NO. RDS - 0005

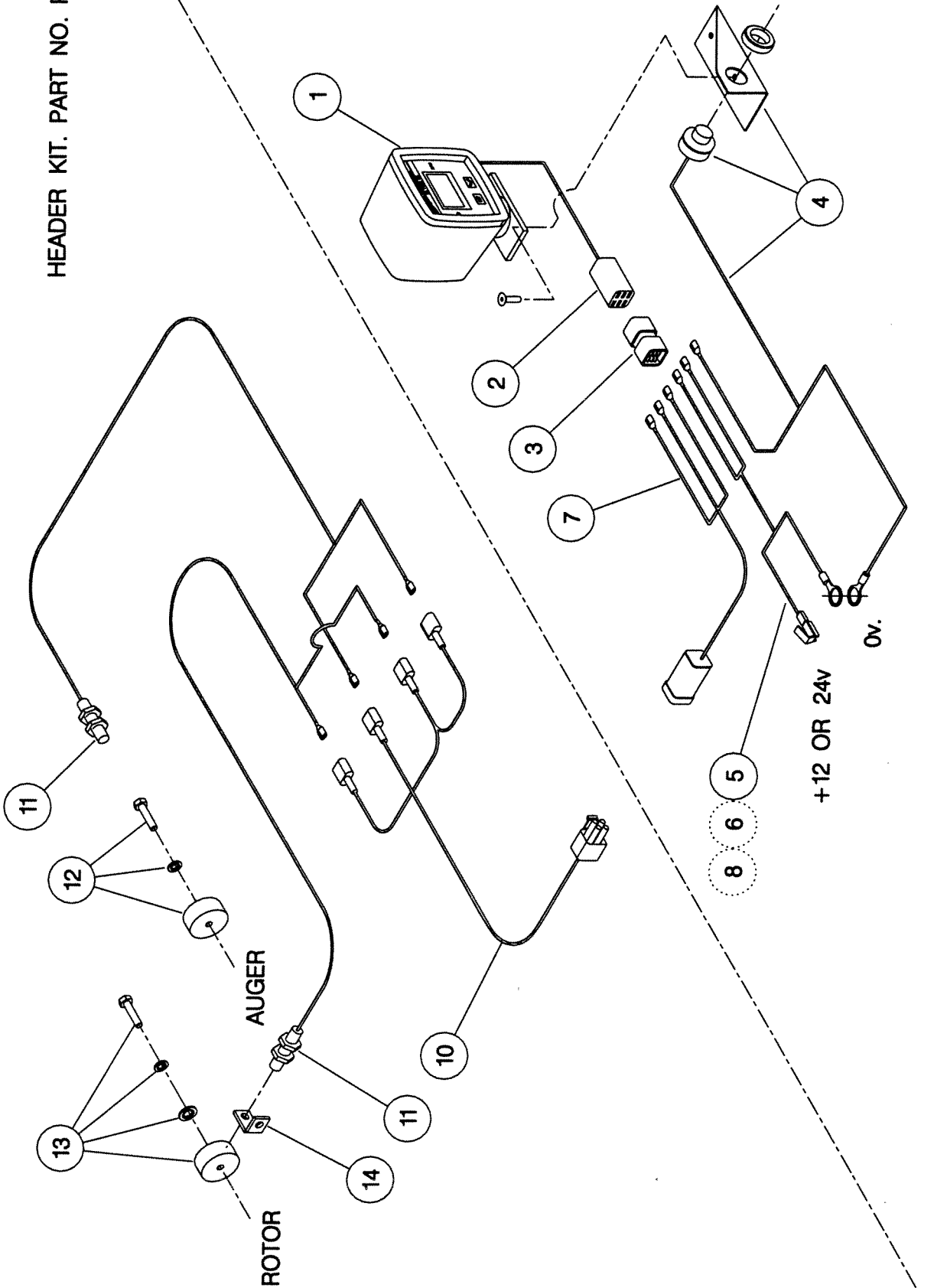

NOTE :

- ITEM 6 IS USED IF POWER SUPPLY IS NOT FUSED.
- ITEM 8 IS USED IF POWER SUPPLY IS 24V, -VE EARTH. (NOT INCLUDED IN RDS - 0001).
- ITEM 4 (ALARM ) IS BUILT INTO ITEM 1 (TACHO HEAD ) ON LATER MODELS.

COMBINE KIT. PART NO. RDS - 0001



# **Shelbourne Header**

**KIT OPTIONS**



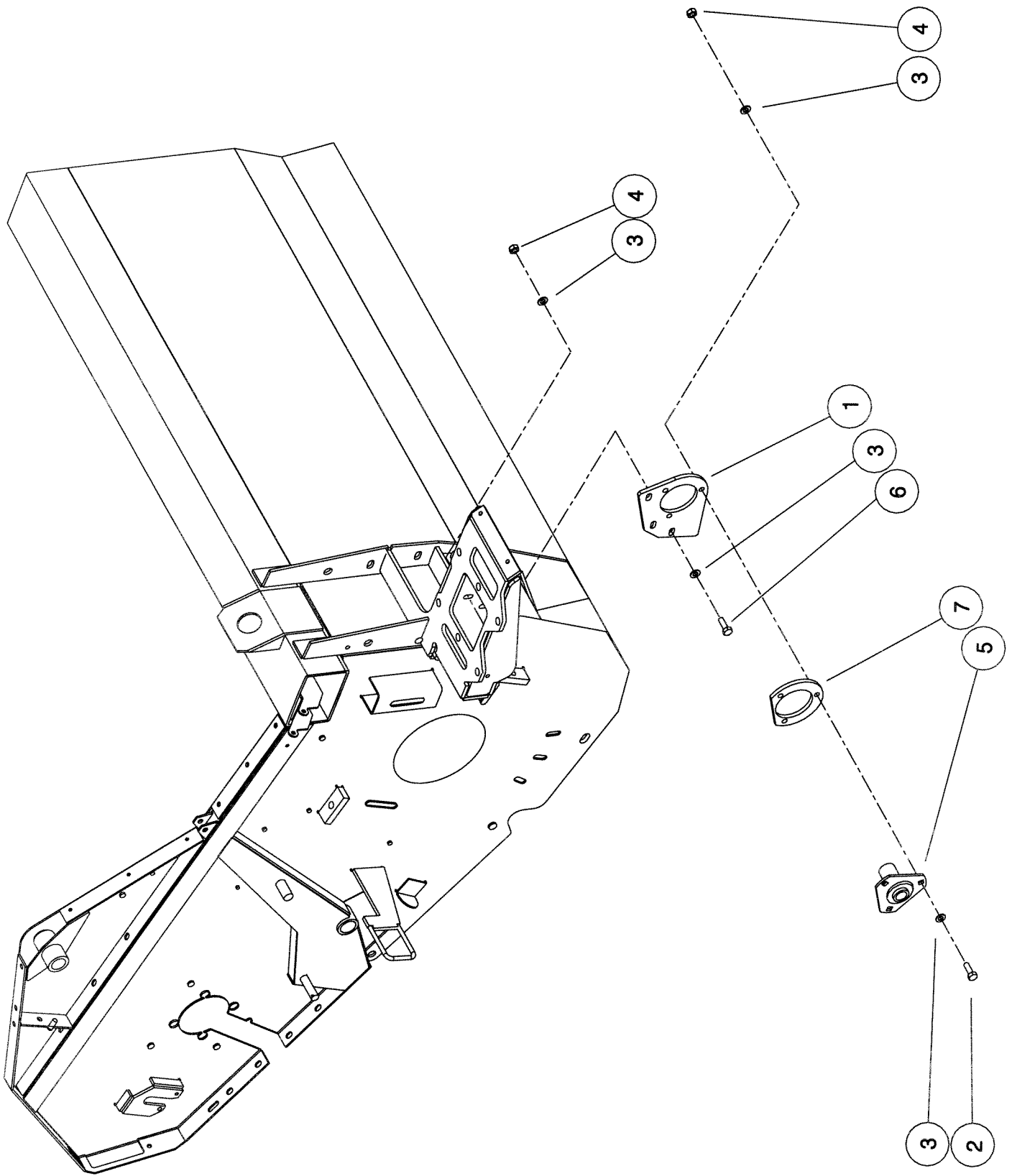



## NUMERIC PARTS LIST

PART No.	PAGE	PART No.	PAGE	PART No.	PAGE
127075 12	34	191777 01	32	192273 01	20
127075 16	34	191798 01	38	192304 01	36
131005	44	191799 01	38	192344 01	8
131014 01	8	191800 01	38	192354 01	20
131041 01	32	191801 01	40	192355 01	20
131063	44	191803 01	40	192363 03	26
131073 04	44	191807 01	40	192364 01	26
190060 06	8	191812	38	192368 01	26
	32	191813	38	192494 01	36
190119 04	32	191819 01	38	192502 01	30
190119 05	6	191821 01	42	192524 09	6
190119 07	36	191822 18	42	192533 01	10
190119 11	36	191822 20	42	192533 02	10
	44	191822 22	42	192537 01	10
190119 22	32	191822 24	42	192537 02	10
190361 01	6	191822 26	42	192543 01	36
190548 01	40	191822 28	42	192550 01	36
190702 04	34	191823 01	42	192555 01	34
191040 01	8	191824 01	42	192570 01	34
	32	191825 01	42	192636 01	16
191259 01	36	191828 01	42	192636 06	16
191259 02	36	191829 01	42	192679 01	13
191339 01	36	191830	42		14
191340 01	36	191831	42	192686 02	6
191355 01	34	191843 01	42	192718 01	6
191359 01	34	191862 01	10		18
191642 01	6	191884 01	40	192732 01	20
191652 01	32	191885 01	42	192738 01	20
191691 02	42	191894 01	40	192738 02	20
191692 01	40	191928 01	40	192763 01	44
191692 02	40	191981 01	6	192812 01	18
191696 02	40	191982 01	34	192813 01	18
191715 01	38	191983 01	34	192839 01	34
191716 01	38	192008 01	44	192876 01	30
191717 01	38	192009 01	44	192876 02	30
191718 01	38	192011 01	26	192890 03	13
191723 01	40	192013 01	44		14
191723 02	40	192014 01	44	192892 01	13
191725 01	40	192038 01	6		14
191735 01	38	192055 01	36	192892 02	13
191737 01	40	192055 02	36		14
191756 01	40	192073 10	36	192892 03	13
191757	40	192193 01	36		14
191759 01	40	192193 02	36	192897 01	14
191763 01	48	192253 02	44	192899 01	13
191765 01	40	192254 01	44	192924 01	42
191770 01	10	192258 01	8	192953 01	34
191774 01	8	192263 01	8	192959 01	13
	32	192265 01	8		14
191777 01	8	192266 01	20	192969 01	20



## NUMERIC PARTS LIST

<u>PART No.</u>	<u>PAGE</u>	<u>PART No.</u>	<u>PAGE</u>	<u>PART No.</u>	<u>PAGE</u>
192970 01	20	193480 02	36	BLTF12570	44
192970 02	20	193504 01	30	BPG-00200	13
192982 07	46	193506 01	36	BRG-0240	16
192985 06	46	193513 01	28		26
	48	193567 01	28	BRG-1994	8
192991 01	46	193828 01	36	BRG-1995	8
192992 01	46	193828 02	36		20
	48	193838 02	6		32
192993 01	46		34	BRG-2020	26
193077 01	50	194061 01	32	BRG-22500	8
193078 01	50	194068 01	32	BRG-24500	46
193103 01	14	194095 01	36	BRG-3220	56
193106 01	50	194098 01	46	BRG-3275	30
193114 01	50	194101 01	36	BRG-5700	42
193117 03	13	194102 01	34	BRG-5800	40
193118 01	13	194103 01	34	BRG-6000	42
	14	194117 01	36	BRG-6600	40
193118 02	13	194181 01	56		42
	14	194183 01	56	BRG-6601	42
193137 01	20	194355 01	26	BRG-6800	42
193203 01	26	194363 01	26	BRG-7000	38
193219 01	36	194363 02	26	BRG-7020	38
193220 01	30	194364 01	34	BRG-7040	38
193221 01	36	195104 01	34	BSH-1530	20
193222 01	36	195140 01	6		32
193229 01	36	195154 01	6	BSH-3030	18
193230 01	36	200035 03	16		36
193231 01	36	200038 01	16	BSH-3070	36
193244 01	36	200120 03	16	BSHZ02553	8
193248 01	36	AUG-02500	26	CHN-0145	34
193251 01	36	BLB-0075	28	CHN-01682	8
193289 13	18	BLT-2316	8	CIR-0470	8
193291 01	30	BLT-2700	36		32
193293 01	20	BLT-3745	16	CIR-1125	8
193295 01	30	BLT-3790	16	CIR-1150	36
193299 01	34	BLT-4710	36	CIR-2700	42
193309 01	20	BLTA06320	20	CIR-3800	42
193310 01	20	BLTA06470	20	CIR-4000	40
193348 01	22	BLTA08350	34	CLP-01012	24
193348 02	22	BLTA08470	34	EDS-11400	34
193363 01	36	BLTA08500	20	EDS-11600	18
193382 01	13	BLTA08530	20	ETM-00440	28
	14	BLTA10290	18	ETM-00560	28
193392 01	34		40	FIT-0213	24
193393 01	34	BLTA10350	20	FIT-0218	42
193395 01	34	BLTA10440	44	FIT-0223	38
193429 01	36	BLTA10520	30		42
193431 01	36	BLTA10530	20	FIT-0253	38
193478 01	34	BLTA12290	32		40
193480 01	36	BLTA12380	36	FIT-0254	38



## NUMERIC PARTS LIST

<u>PART No.</u>	<u>PAGE</u>	<u>PART No.</u>	<u>PAGE</u>	<u>PART No.</u>	<u>PAGE</u>
FIT-0255	40	HSSF12204	26	NUT-0269	20
FITD00005	40	HSSG10204	13		30
GEA-0095	32		14		36
GEA-0102	32	HSSG12174	32	NUT-0271	8
GEA-0135	32	K0807035	8	NUT-0580	16
GSTA14406	18	K0807050	16	NUT-3000	40
HHBC34610	24	K0807060	16	NUT-3010	38
HHBC59610	24	K1008045	40	NUTA07120	30
HPPD07100	24	KIT-00115	16	ORA260000	42
HSS-0084	20	KIT-00424	32	PIN-01790	36
	20	KIT-00525	32	PIN-1150	16
	34	KIT-00976	13		36
	36	LMP-10501	28	PIN-1168	42
HSS-0086	8	LTC-00040	34	POP-0006	6
	24	NIP-0001	18		34
	36		36		36
HSS-0092	36	NIP-00600	50	PSP-01201	20
HSS-0140	6	NUT-0012	40	PSP-01800	20
	30	NUT-0164	30	PTO-00123	46
	34		34	PTO-09010	32
	36	NUT-0170	16	PTO-24000	46
HSS-0145	34		36	RCL-0015	34
HSS-0155	10		44	RCXPACK1	4
HSS-0188	40		46	REF	40
HSS-0191	10	NUT-0260	8		40
	20		20		40
	26		24	RX72FB2	4
	36		26	RX72FB3	4
	38		34	RX72RSFB1	4
HSS-0194	36		36	RX72RSFB4	4
	42		36	SCBA08172	26
HSS-0198	50	NUT-0263	20	SCCA10412	26
	56		26	SCW-0139	38
HSS-0202	40		30	SCW-0190	38
	56		34		40
HSS-0235	30		36	SCW-0196	40
HSS-0238	32	NUT-0265	10	SCW-0515	30
	46		16	SCW-1735	36
HSS-0241	16		18	SCW-1740	36
	30		20	SCW-4530	50
	32		26	SCW-4535	16
HSS-0260	36		30	SCW-4700	34
HSS-0265	20		36	SCW-4760	42
HSS-0275	46		44	SCW-4959	26
HSS-0315	20		50	SCW-4960	26
HSS-0316	36		56		36
HSS-0318	8	NUT-0269	8	SCW-5104	46
HSSA10680	20		16		48
HSSF08174	13		32	SCW-5180	13
	14		46		28
HSSF10174	40				



## NUMERIC PARTS LIST

<u>PART No.</u>	<u>PAGE</u>	<u>PART No.</u>	<u>PAGE</u>	<u>PART No.</u>	<u>PAGE</u>
SCW-5180	14	WSH-0024	20		
	24	WSH-0030	16		
	46	WSH-0056	20		
SEA-0550	42		26		
SEA-0565	42		34		
SEA-0590	38		36		
SEA-0600	38	WSH-0058	6		
SEA-0610	40		10		
SPGA32221	20		26		
TNF-0010	34		34		
TNF-0011	34		38		
TNF-0012	34	WSH-0061	18		
TPE-00250	28		20		
	28		26		
TPE-00251	28		36		
	28		38		
WSH-0009	8		40		
	20		42		
	24	WSH-0065	30		
	26		32		
	34	WSH-0070	8		
	36		20		
WSH-0012	20		36		
	26	WSH-1034	13		
	30		14		
	34	WSH-1038	34		
	36	WSH-1301	38		
	40		40		
WSH-0015	10		42		
	16	WSH-1547	36		
	18	WSH-6000	40		
	20	WSH-6010	38		
	26				
	30				
	36				
	40				
	46				
	48				
	50				
	56				
WSH-0018	8				
	16				
	20				
	30				
	32				
	36				
	44				
	46				
WSH-0024	8				
	36				

