

# **SHELBOURNE REYNOLDS**

## **STRIPPER HEADER PARTS LIST**

### **SR3000 MULTI-PLATE STD**



**Shelbourne Reynolds Engineering Ltd, Shepherds Grove, Stanton,  
Bury St Edmunds, Suffolk IP31 2AR  
Telephone: Stanton (0359) 50415  
Fax.No (0359) 50464**

GRAIN STRIPPER PARTS MANUAL

Your Shelbourne Reynolds stripper header is designed to fit many different types of combine.

For this reason the machine number index is broken down into sections for identification. Your machine numbers are listed below:

- STRIPPER HEADER \_\_\_\_\_
- ADAPTOR PLATE \_\_\_\_\_
- DRIVE KIT \_\_\_\_\_
- HYDRAULIC FITTING \_\_\_\_\_
- OTHER OPTIONS \_\_\_\_\_  
\_\_\_\_\_  
\_\_\_\_\_  
\_\_\_\_\_

This manual contains all parts common to the stripper header and is used in conjunction with the combine fittings manual, which contains the adaptor plate, and drive kit parts and fitting, and any other options available.

Machine Identification

The stripper header machine identification number is engraved on a plate on the top right hand corner of the header.

The adaptor plate has a plate on the top right hand corner also with the adaptor plate assembly number engraved on it.

The drive kit can be identified by description, and use of the drive kit identification number marked above.

Ordering Spare Parts

To ensure that you order the correct part from your SRE dealer please use the following procedure.

Always quote the serial number and stripper head number from the plate on the top right hand corner of the stripper head. Always quote the adaptor plate assembly number from the plate on the top right hand side of the adaptor plate.

Refer to the front of this parts list book (machine assemblies), decide if the part you want is on:

Stripper Head  
Adaptor Kit  
Drive Kit

If your part is on the Adaptor Kit, identify by matching the part number from the adaptor plate with that in the top left hand corner of the parts lists. You will find the appropriate drawing accompanying the parts list.

If the part you require is on the drive kit, ensure that you have the parts listing for the correct combine model and width. Then progress through to the next drawing following that list, for indication of that part.

If the part you require is on the stripper head assembly, identify the appropriate assembly by matching the part number from the stripper head with the page with the same number marked on the top left hand side.

Use the following sub assembly numbers and descriptions to find the area of the machine that your part is required, i.e. you need a part which is fitted to the conveyor, your part will be in the conveyor assembly parts list.

Having decided which sub-assembly your part should be under, use the number beside that sub-assembly description which will begin with 1960-- -- to find the parts listing of the sub-assembly further on in the manual. The number will be printed in the top left hand corner, the sub-assemblies are in numerical order.

Having found the correct parts list, you will find the corresponding drawing by processing through the manual to the next drawing.

The drawings indicate the components by item numbers which you will find are repeated in the left hand side of your parts listing, and therefore referring to the correct part.



Shelbourne Reynolds Engineering Limited



ASSY NUMBER

196515 01

ASSY DESCRIPTION: MKII GRAIN STRIPPER 3.0M MULTI PLATE

ITEM	PART NO	DESCRIPTION	QTY	ITEM	PART NO	DESCRIPTION	QTY
1	196028 06	CONVEYOR ASSY	1				
2	196029 06	AUGER ASSY	1				
3	196030 02	DRIVE COMPONENTS	1				
4	196031 01	FRAME & COMPONENTS	1				
5	196032 03	ASSY COMPONENTS	1				
6	196010 07	STRIPPING ROTOR 3.0M	1				
7							
8	196027	CROP DIVIDERS	1				
9	196035 01	HYDRAULICS	1				
10	196036 01	EMBLEMS & GUARDS	1				
11	196034 01	DRIVE KIT	1				

ERE

## Shelbourne Reynolds Engineering Limited

ERE

ASSY NUMBER

196516 01

ASSY DESCRIPTION: MKII GRAIN STRIPPER 3.0M MULTI PLATE

ITEM	PART NO	DESCRIPTION	QTY	ITEM	PART NO	DESCRIPTION	QTY
1	196028 06	CONVEYOR ASSY	1				
2	196047 01	AUGER ASSY	1				
3	196043 02	DRIVE COMPONENTS	1				
4	196031 01	FRAME & COMPONENTS	1				
5	196032 03	ASSY COMPONENTS	1				
6	196010 07	STRIPPING ROTOR 3.0M	1				
7							
8	196027	CROP DIVIDERS	1				
9	196035 01	HYDRAULICS	1				
10	196036 02	EMBLEMS & GUARDS	1				
11	196034 01	DRIVE KIT	1				

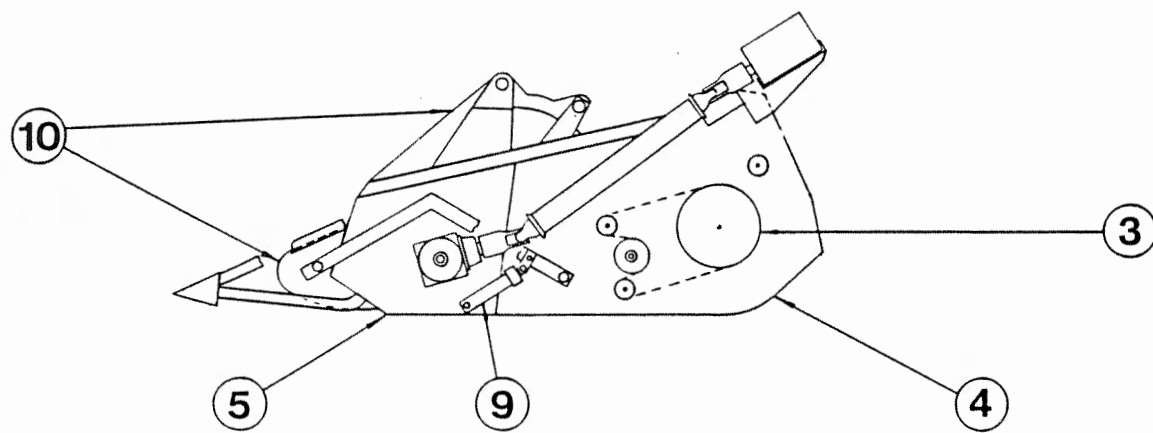
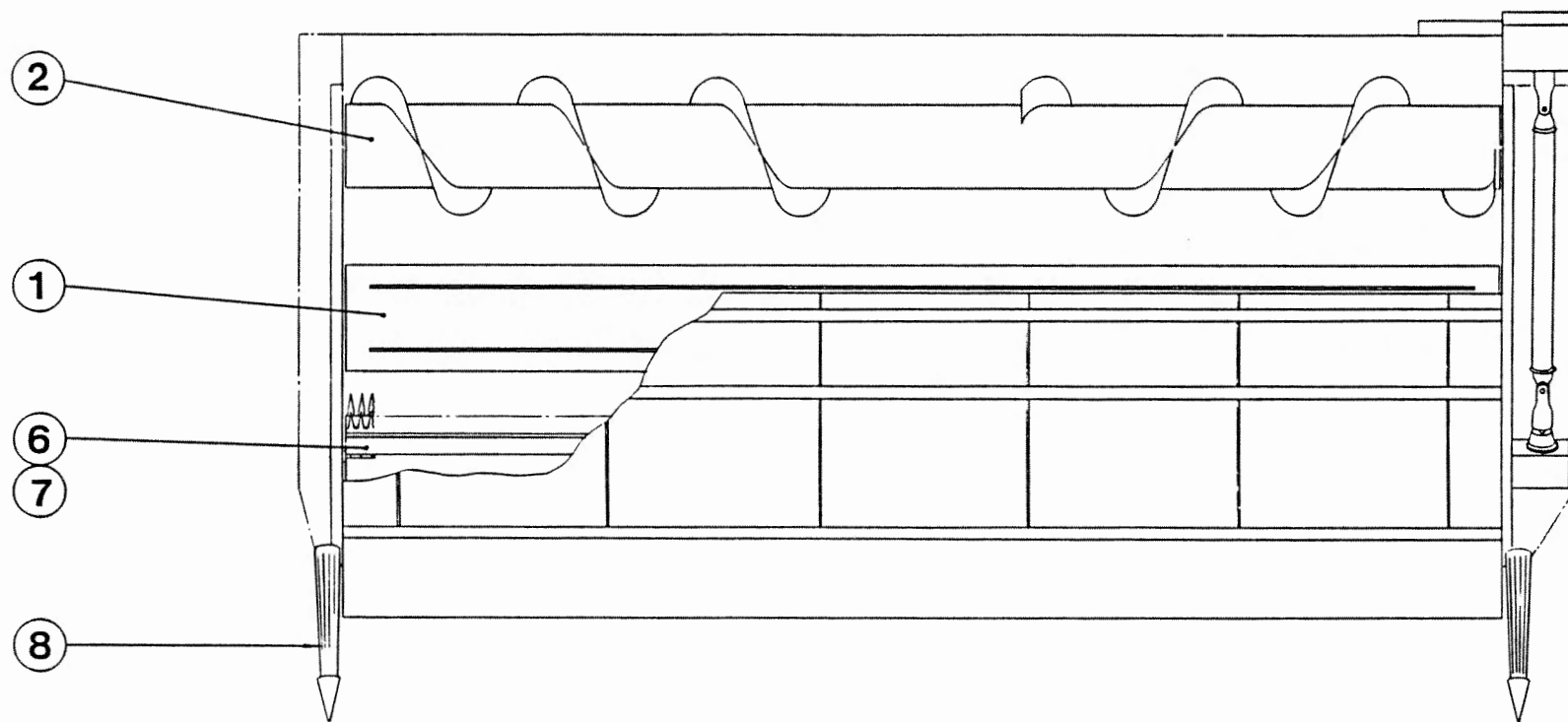



Shelbourne Reynolds Engineering Limited



ASSY NUMBER: 196010 07

ASSY DESCRIPTION: STRIPPING ROTOR ASSY 3.0M MK2

ITEM	PART NO	DESCRIPTION	QTY	ITEM	PART NO	DESCRIPTION	QTY
1	191364 01	ROTOR SECTION	8				
2	190549 01	ROTOR SECTION PL RH	4				
3	190549 02	ROTOR SECTION PL LH	2				
4	191357 01	ROTOR BLADE	24				
5	SCW-5180	SCREW	32				
6	191501 02	ROTOR SHAFT ASSY	1				
7	190008 01	ROTOR END COVER	2				
8	HSS-0147	BOLT	240				
9	191313 01	ANTI WRAP PLATE LH	8				
10	WSH-0058	WASHER	240				
11	HSS-0191	BOLT	18				
12	WSH-0015	WASHER	36				
13	NUT-0265	NUT	18				
14	191313 02	ANTI WRAP PLATE RH	8				
15	191630 01	ANTI-WEAR STRIP	32				
16	190760 01	END BLANKING PLATE RH	1				
17	190760 02	END BLANKING PLATE LH	1				
18	HSS-0135	SCREW	160				
19	WSH-1300	WASHER	160				
20	191357 04	ROTOR BLADE	16				
21	191471 01	ANTI WRAP ADJ PLATE	16				
22	191630 02	ANTI-WEAR STRIP (RH)	8				
23	191630 03	ANTI-WEAR STRIP (LH)	8				
24	WSH-1034	WASHER	32				

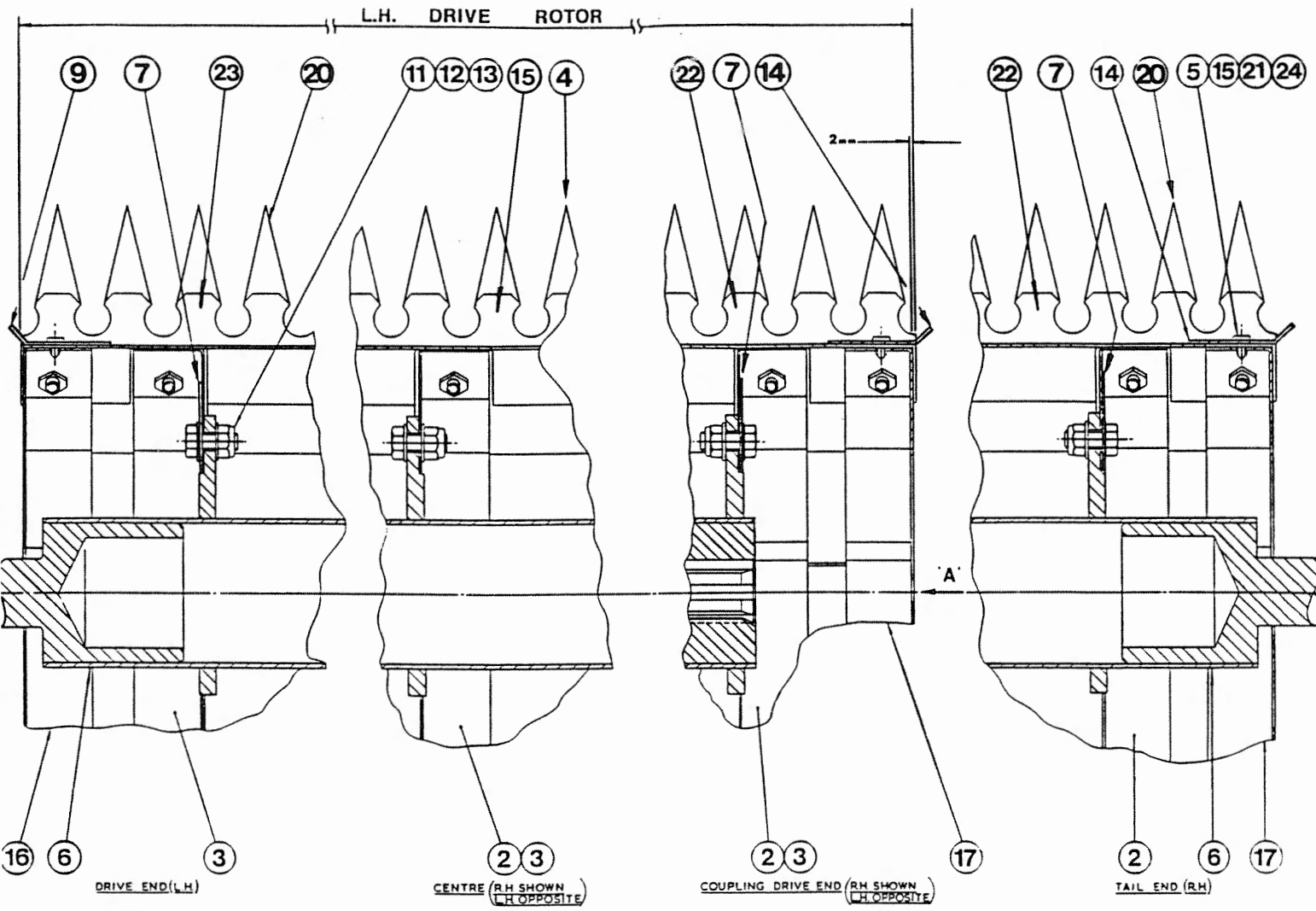

**STRIPPING ROTOR ASSEMBLY**

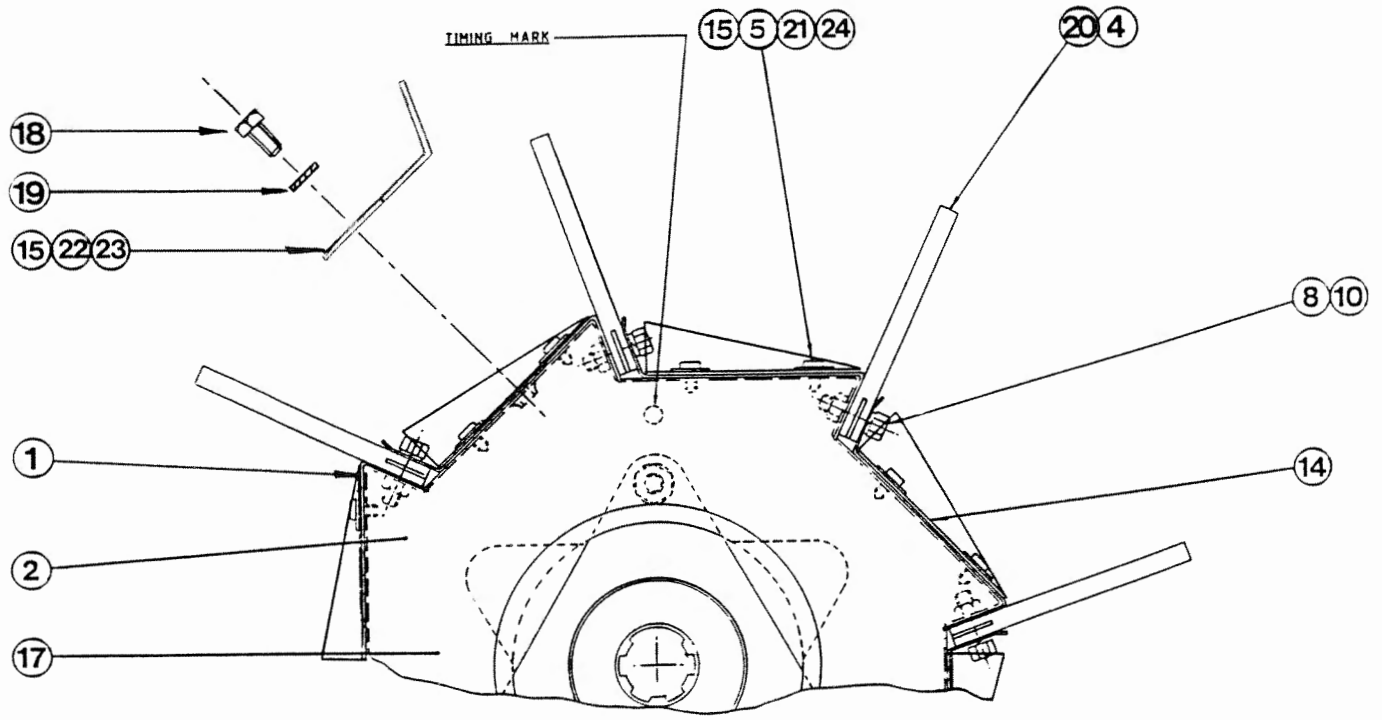

VIEW ON ARROW A

**ASSEMBLY OF ROTOR**  
 ALWAYS START AT THE SPLINED END.  
 FOR L.H. ROTORS - 1st SECTION PLATE R.H. ITEM 2  
 FOR R.H. ROTORS - 1st SECTION PLATE L.H. ITEM 3  
 ALIGN TIMING HOLE ON SECTION PLATE WITH HOLE IN THE TRIANGULA  
 PLATE WHICH IS IN LINE WITH THE MASTER SPLINE.  
 FOLLOWING SECTION PLATES ARE ASSEMBLED WITH THE TIMING HO



ASSY NUMBER: 196027

ASSY DESCRIPTION: DIVIDER

ITEM	PART NO	DESCRIPTION	QTY	ITEM	PART NO	DESCRIPTION	QTY
1	190931 01	DIVIDER ARM LH	1				
2	190931 02	DIVIDER ARM RH	1				
3	190929	DIVIDING PLATE	2				
4	190930	INNER DEFLECTOR	2				
5	190927	BRACKET ASSEMBLY	2				
6	190928	BRACKET ASSEMBLY	2				
7	190926	ADJUSTER ROD	2				
8	DIV-0001	NOSE CONE	2				
9	DIV-0005	SHOE	2				
10							
11	HSS-0235	SCREW	2				
12	PIN-1167	SPLIT PIN	2				
13	HSS-0194	SCREW	10				
14	HSS-0160	SCREW	2				
15	WSH-0012	WASHER	2				
16	NUT-0265	NUT	8				
17	WSH-0015	WASHER	20				
18	NUT-0271	NUT	2				
19	WSH-0024	WASHER	2				
20	WSH-0061	SPRING WASHER	6				
21	HSS-0198	SCREW	4				
22	NUT-0170	NUT	2				
23	NUT-0167	NUT	6				
24	ACL-0013	R CLIP	2				
25	CHN-0145	CHAIN	2				
26							
27	WSH-0009	WASHER	4				
28	NUT-0260	NUT	2				

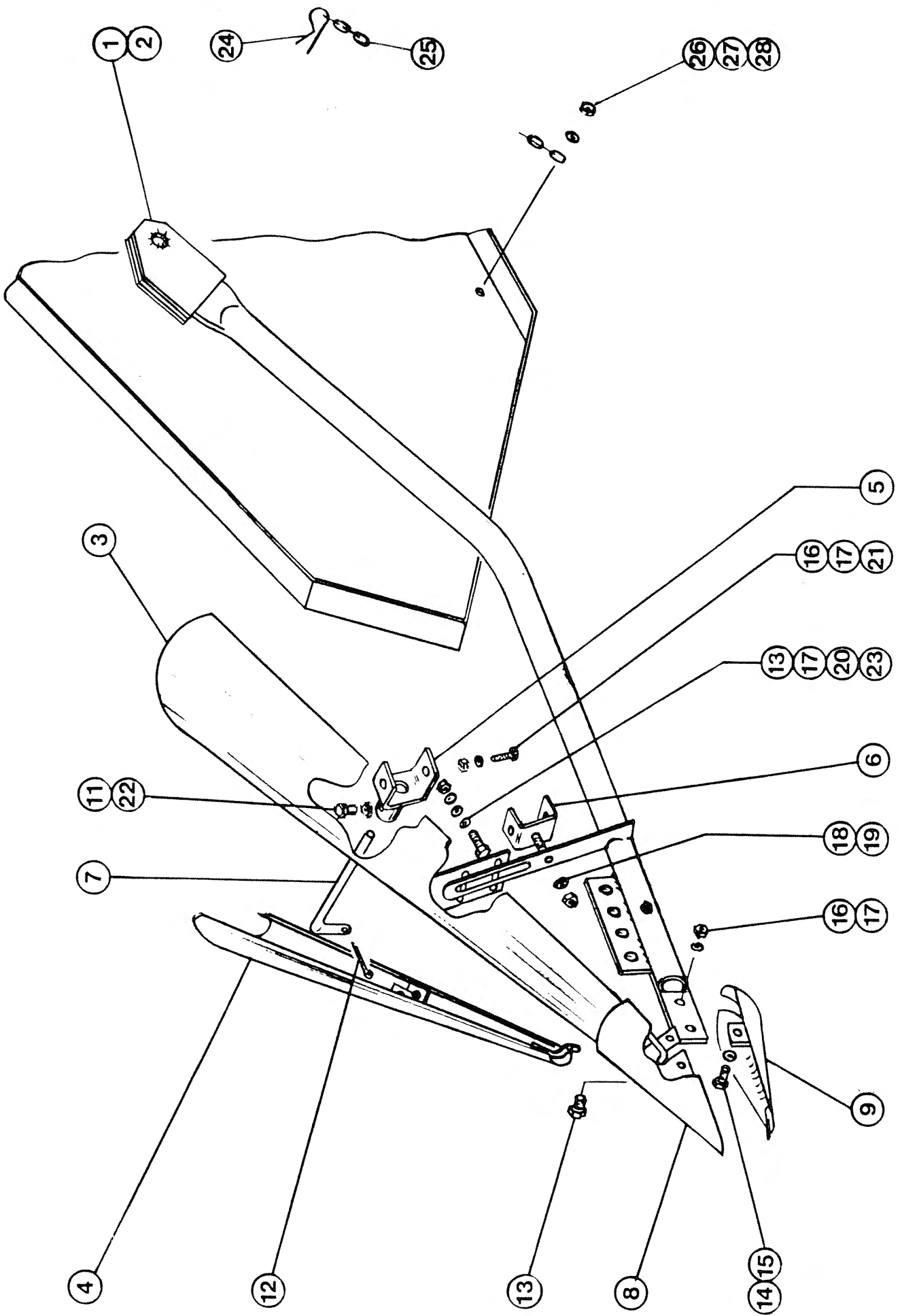

ASSY NUMBER:

196028 06

ASSY DESCRIPTION: CONVEYOR ASSY (3.0)

ITEM	PART NO	DESCRIPTION	QTY	ITEM	PART NO	DESCRIPTION	QTY
1	191502 02	DRIVE ROLLER (3.0)	1	39	HSS-0135	SCREW	2
2	BRG-2020	BEARING	2	40	SPG-0060	SPRING	1
3	NUT-0170	NUT	2	41	190114 01	SPRING ADJ	1
4	WSH-0018	WASHER	2				
5	SCW-0514	BOLT	6	45	190174 01	SEAL SUPPORT (OUTER)	2
6	NUT-0265	NUT	6	46	190174 02	CLAMP STRIP (OUTER)	2
7	WSH-0015	WASHER	6	47a	190174 03	SEAL STRIP (OUTER) LH	1
8	K0807030	KEY	1	47b	190174 04	SEAL STRIP (OUTER) RH	1
9	190018 11	ROLLER (3.0)	1	49	CIR-1125	CIRCLIP	2
10	BRG-3358	BEARING	4				
11	CIR-0620	CIRCLIP	2	57	SCW-4528	SCREW	2
13	191503 02	ROLLER ADJ SHAFT (3.0)	1	59	SCW-3696	SCREW	6
14	WSH-1520	WASHER	4	60	WSH-0056	WASHER	12
15	BSH-3040	BEARING	2				
				62	HSS-0088	SCREW	12
17	BSH-3060	BEARING	1	63	WSH-0058	WASHER	3
				64	HSS-0130	SCREW	1
20	190023 02	BELT SUPPORT	2	65	PIN-1928	PIN	1
22	190022 03	CONVEYOR BELT	1	71	190596 04	STUB SHAFT ENDS	2
23	190024 01	ADJ ARM	1	72	190596 03	SPACER TUBE	2
25	190025 01	MTG BRACKET	2				
26	190730 02	TRACKING ARM LH	1				
27	191505 01	TRACKING ARM ASSY	1				
28	190027 06	TRACK ROD ASSY	1				
29	190027 03	ADJ BLOCK	1				
33	190029 01	RETAINING WASHER	2				
34	HSS-0140	SCREW	1				
36	HSS-0210	SET SCREW	1				
37	NUT-0167	NUT	2				
38	WSH-0061	WASHER	1				

CONVEYOR ASSEMBLY

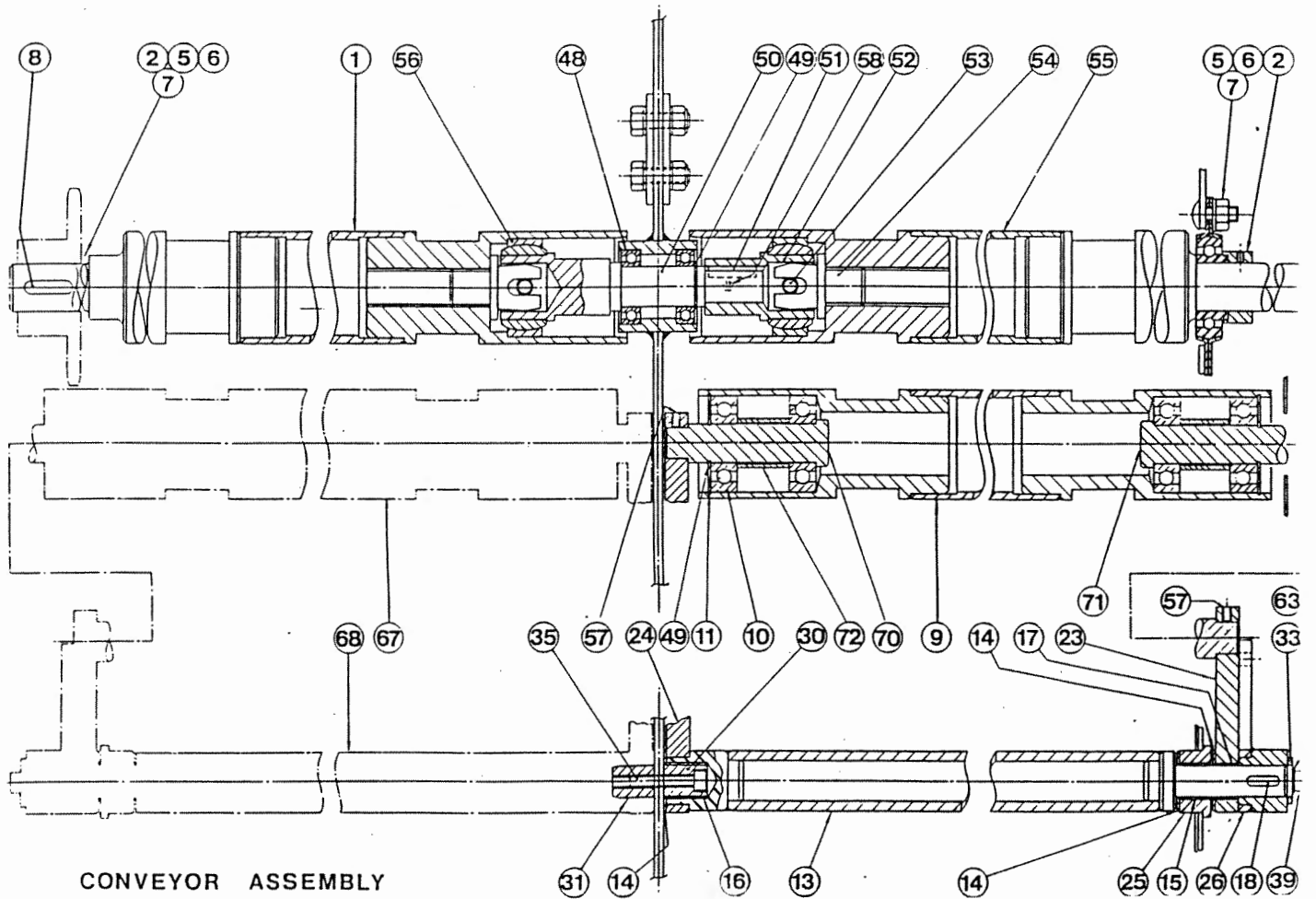
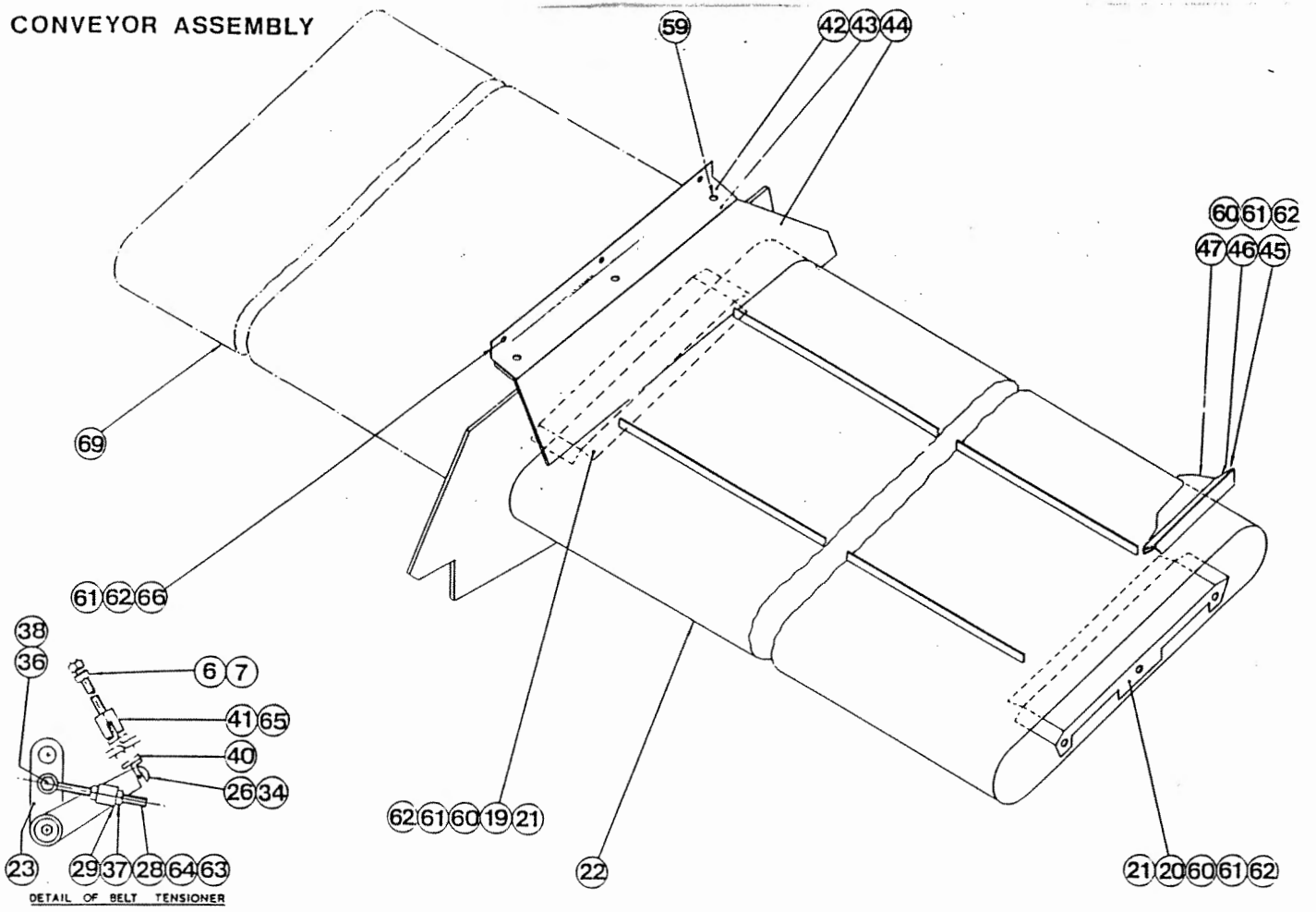

CONVEYOR ASSEMBLY



Shelbourne Reynolds Engineering Limited



ASSY NUMBER:

196029 06

ASST DESCRIPTION:

AUGER (3.0M)

ITEM	PART NO	DESCRIPTION	QTY	ITEM	PART NO	DESCRIPTION	QTY
1	191628 01	AUGER	1	38	WSH-0065	WASHER	4
2	132019 01	COVER PLATE	1	39	BLT-2135	BOLT	9
3	BRG-4160	BEARING	3	40	NUT-0263	NUT	6
4	190546 01	AUGER CRANK	1	41	BLT-2197	BOLT	3
5	132010 01	BUSH FOR FINGER	15	42	SCW-4960	SCREW	44
6	190547 01	FINGER	14	43	190735 02	BLANKING PLATE	1
7	132011	FINGER PLATE COMCAVE	14	44	NUT-0260	NUT	30
8	132012	FINGER PLATE CONVEX	14	45	WSH-0056	WASHER	14
9	132013	FINGER GUIDE	14	46	PIN-1167	SPLIT PIN14	
10	131095 03	KEY	1	47	SCW-4530	SCREW	2
11	190545 01	AUGER CLAMP	1	48	BLT-3812	COACH BOLT .	4
12	191629 01	AUGER SHAFT	1	49	NUT-0170	NUT	8
13	190208	FINGER ADJUSTER	1	50	BLT-2240	BOLT	1
14	K0807060	KEY	1				
15	191005 02	AUGER ADJUSTER R. H.	1	52	SCW-1975	SCREW	4
16	190585 06	VERTICAL ADJUSTER	2	53	131024 05	SPROCKET	1
17	190585 04	HORIZONTAL ADJUSTER	2	54	WSH-0009	WASHER	14
18	132018 02	AUGER DRIVE SHAFT	1	55	WSH-0018	WASHER	6
19	BRG-0240	BEARING	1	56	PIN-1150	SPLIT PIN	1
20	191005 01	AUGER ADJUSTER L. H.	1				
21	132022 01	SPACER	1				
22	131025	HUB	1				
23	131005	CLUTCH PLATE	2				
24	131055 01	DRIVE PLATE	1				
25	131024 01	SPROCKET	1				
26	131063	SPRING	4				
27	131073 01	SPACER	4				
28	K0807050	KEY	1				
29	191006 01	SPACER	4				
30	BLT-2273	BOLT	4				
31	124048 01	WASHER	4				
32	NUT-0269	NUT	13				
33	NUT-0580	NUT	1				
34	WSH-0030	WASHER	1				
35	HSS-0191	SET SCREW	3				
36	NUT-0265	NUT	6				
37	BLT-2243	BOLT	4				

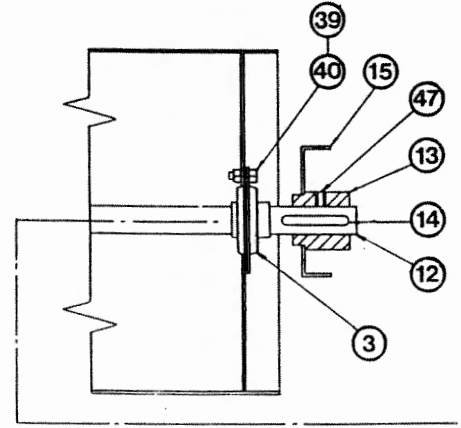
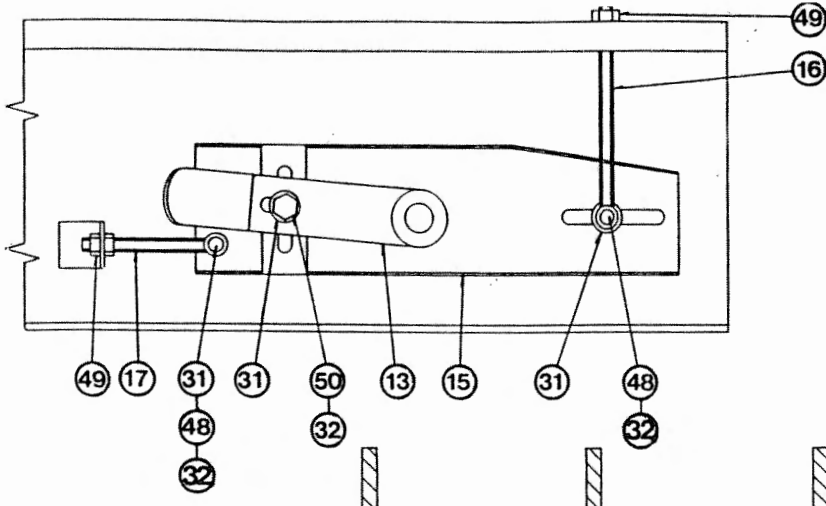

AUGER ASSEMBLY

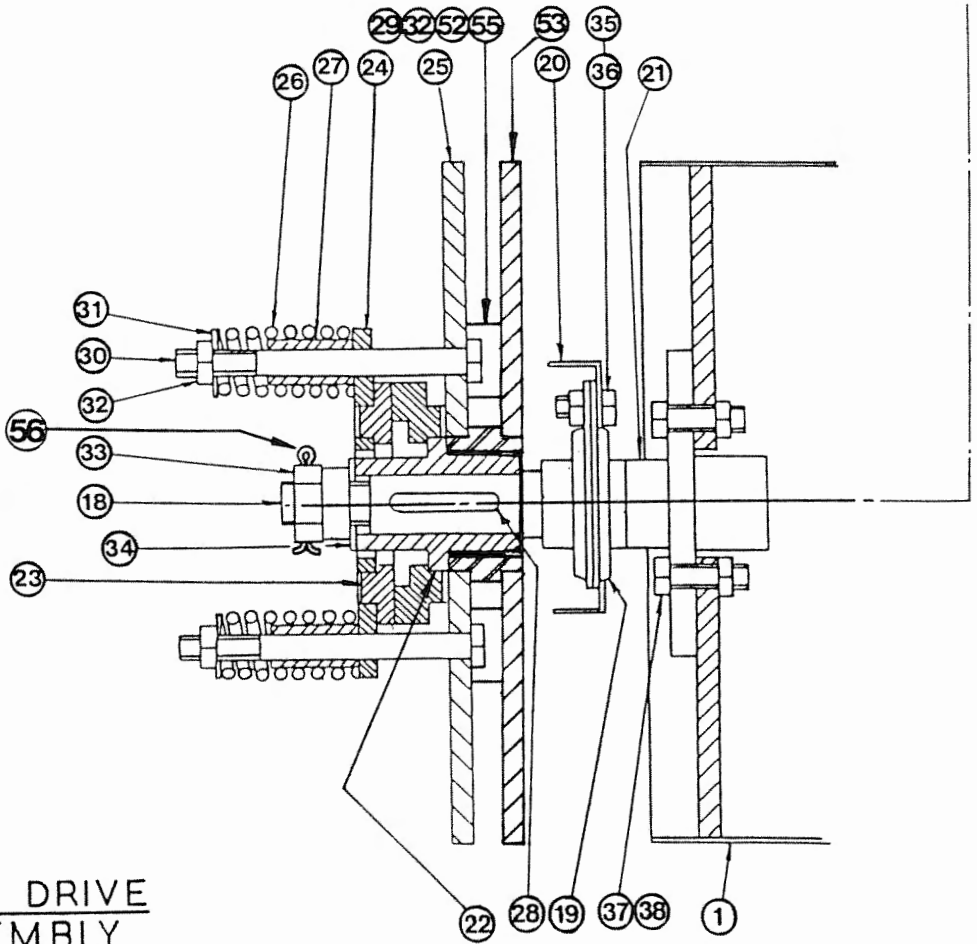
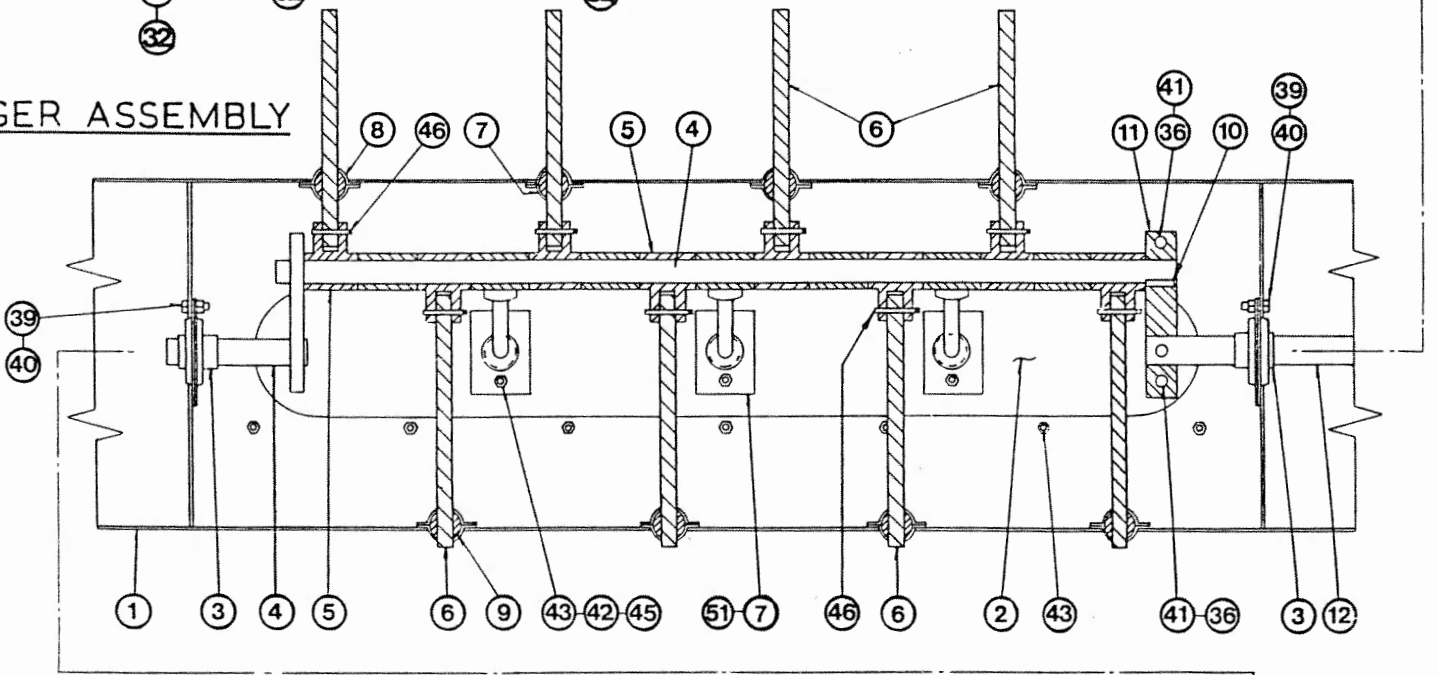

AUGER DRIVE ASSEMBLY



Shelbourne Reynolds Engineering Limited



ASSY NUMBER:

196030 02

ASSY DESCRIPTION:

DRIVE COMPONENTS C. T. MKII MULTI PLATE

ITEM	PART NO	DESCRIPTION	QTY	ITEM	PART NO	DESCRIPTION	QTY
1	131014 01	SPROCKET IDLER	3				
2	BRG-1995	BEARING	3				
3	CIR-0470	CIRCLIP	3				
4	190060 06	CONVEYOR IDLER SPINDLE	2				
5	191039 01	IDLER ADJ SCREW	2				
6	191040 01	CONVEYOR IDLER SPACER	2				
7	190057 01	CONVEYOR SPROCKET	1				
8	SCW-4535	SCREW	2				
9	K1008150	KEY	1				
10	NUT-0271	NUT	1				
12	190060 07	AUGER IDLER SPINDLE	1				
13	191040 02	AUGER SPACER	1				
14	CHN-0020	CHAIN	103				
15	CHN-0111	JOINER	1				
21	GEA-0090	BEVEL GEARBOX	1				
22	PTO-09001	POWER SHAFT(W2400 SERIES, CC630 OVERUN CLUTCH & 800NM TORQUE LIMITER TUBE 1B2a NO GUARDS)	1				
25	WSH-0018	WASHER	2				
26	NUT-0170	NUT	2				
27	GEA-0080	SIX SPEED GEARBOX ASSY	1				

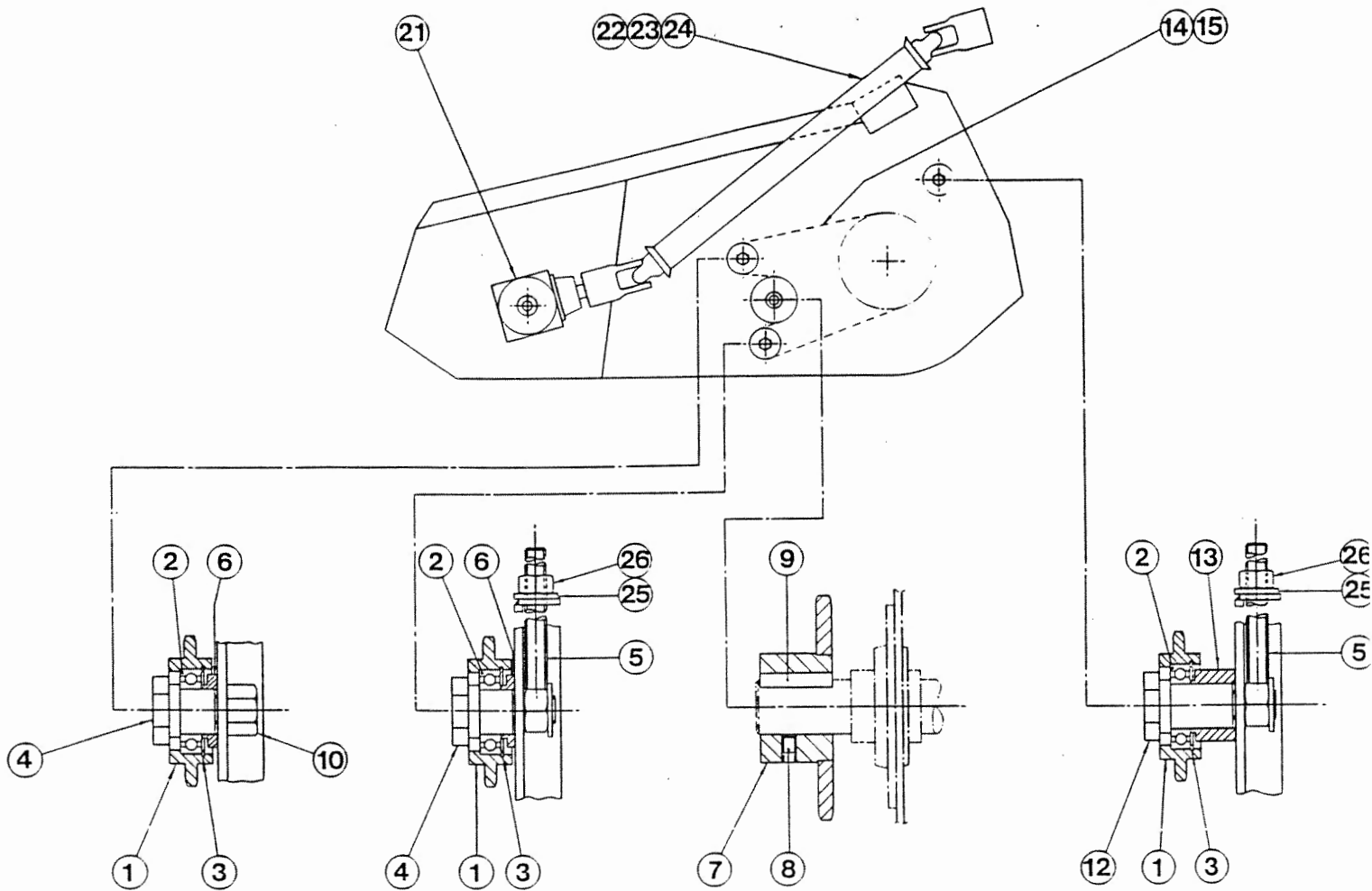

DRIVE COMPONENTS

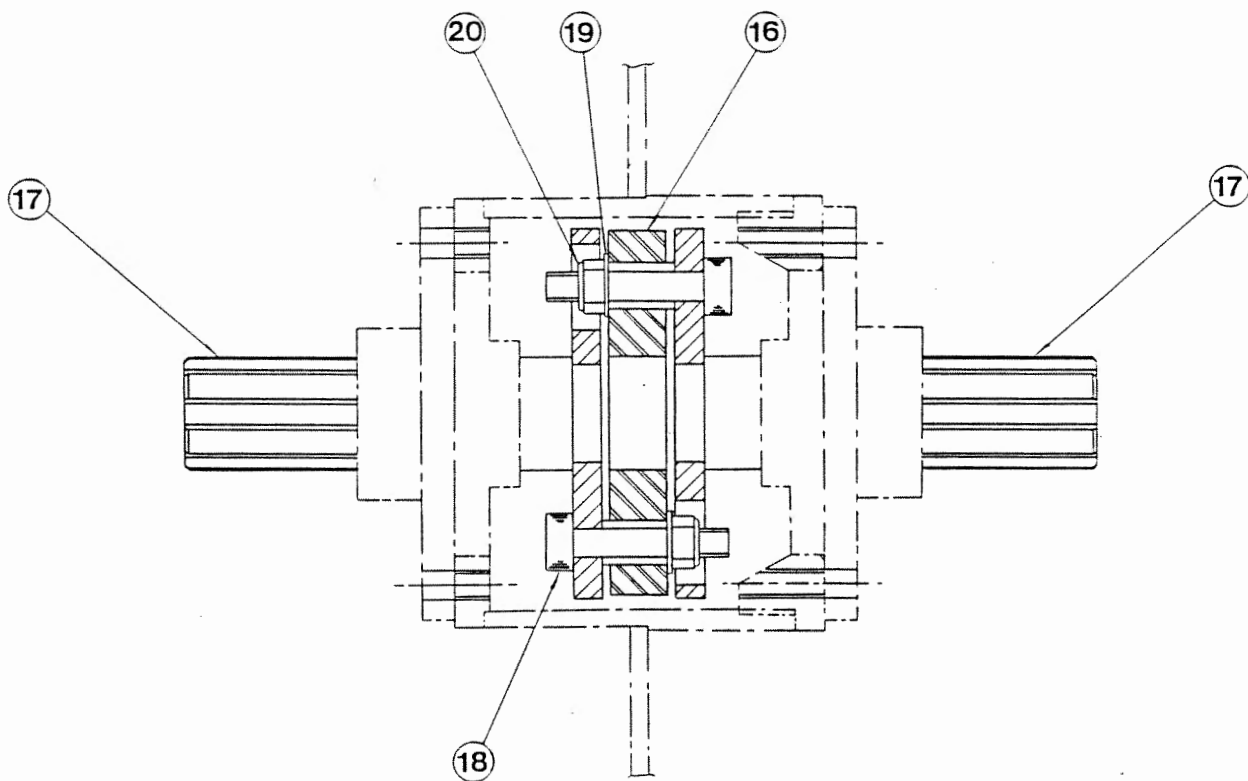

DRIVE COMPONENTS

NOTE - TORQUE ITEMS 24 & 26 TO 77 N/M





Shelbourne Reynolds Engineering Limited



ASSY NUMBER:

196031 01

ASSY DESCRIPTION: MK II 3.0M ASSY COMPONENTS

ITEM	PART NO	DESCRIPTION	QTY	ITEM	PART NO	DESCRIPTION	QTY
1	191627	FRAME ASSY	1				
2	191513	FRAME ASSY					
3	191500 02	COWL ASSY	1				
4	191498 02	ADJUSTER CROP DEFLECTOR	1				
6	190590 04	RUBBER SEAL	1				
8	NUT-0260	NUT	20				
9	SCW-3696	SCREW	20				
10	190590 01	CLAMP STRIP	5				
11	191034 07	STRIPPER PLATE	2				
12	BLT-4710	BOLT	6				
13	NUT-0263	NUT	6				
14	WSH-0012	WASHER	6				

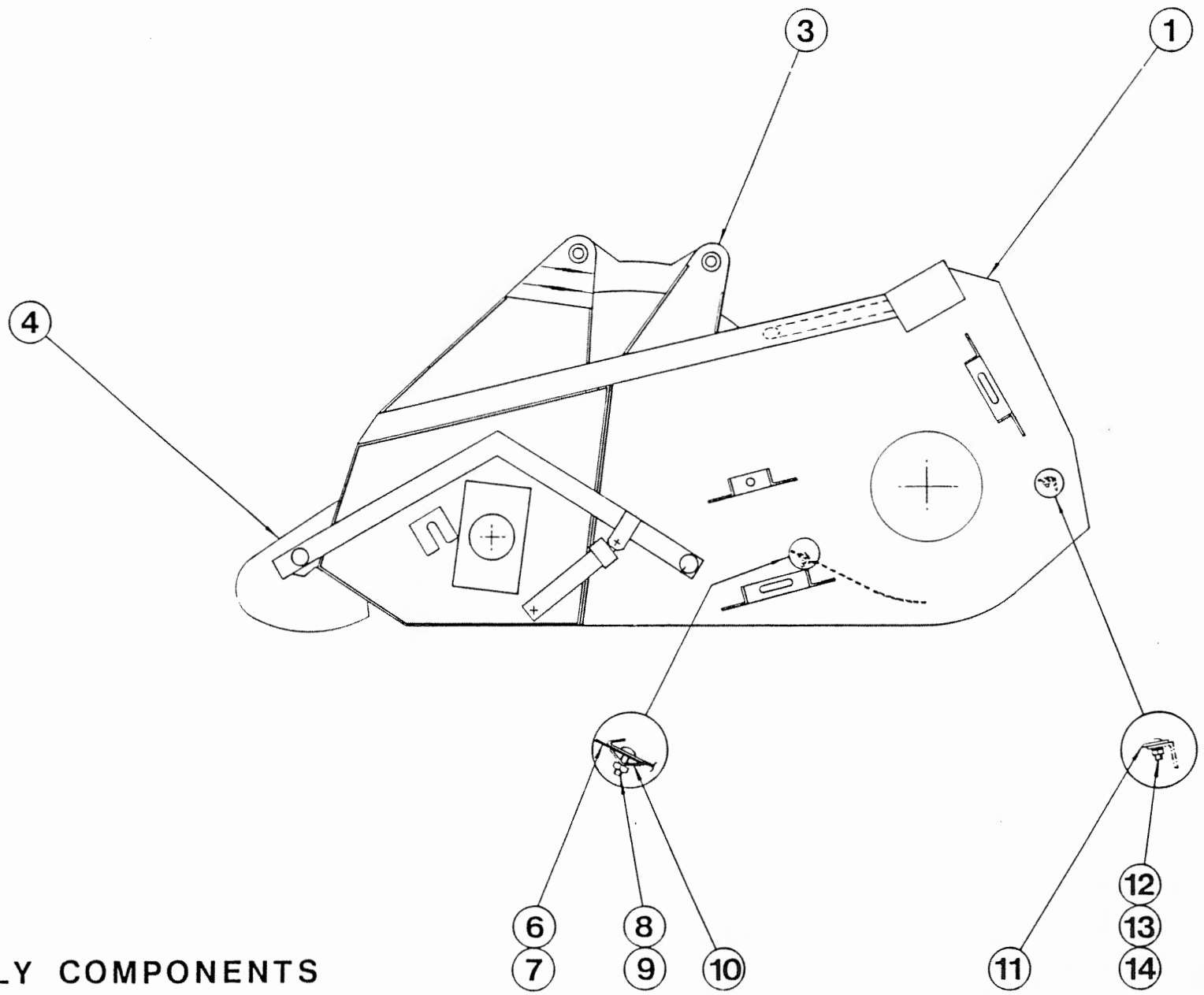

ASSEMBLY COMPONENTS



Shelbourne Reynolds Engineering Limited



ASSY NUMBER: 196032 03

ASSY DESCRIPTION: ASSY PARTS MKII CT MULTI PLATE

ITEM	PART NO	DESCRIPTION	QTY	ITEM	PART NO	DESCRIPTION	QTY
1	191611	BEARING ASSY	2	34	HSS-0315	BOLT	8
2				35	WSH-0024	WASHER	8
3				36	HSS-0140	SCREW	8
4	190050	HYD RAM TOP PIN & BRKT	2	37	NUT-0260	NUT	10
5	190790 01	LEVER ARM ASSY RH	1	38	WSH-0012	WASHER	12
6	190790 02	LEVER ARM ASSY LH	1	39	WSH-0070	WASHER	8
7	191262 01	PIVOT PIN	2	40	HSS-0238	SCREW	6
8	190052 01	RETAINING WASHER	2	41	HSS-0194	SCREW	7
9	BSH-3030	BEARING	2	42	WSH-1515	WASHER	14
10	HSS-0140	SCREW	4	43	NUT-0265	NUT	7
11	HSS-0188	SCREW	2	44			
12	WSH-0058	WASHER	4	45	190896 04	ROTOR SPACER	2
13	WSH-0061	WASHER	10	46	190917 01	ADJ COWL STOP LH	1
14	K0807025	KEY	2	47	190917 02	ADJ COWL STOP RH	1
15	HSS-0145	SCREW	2	48	191324 01	CLAMP STRIP	2
16	BRG-0250	BEARING	2	49	191325 01	RUBBER SEAL	2
17				50	POP-0006	POP RIVET	12
18	190478 01	DIVIDER HEIGHT ADJ	2	51	191592 01	WEAR PLATE	2
19	191508 01	SIDE FRAME RH	1	52	SCW-1995	SCREW	4
20	191508 02	SIDE FRAME LH	1	53	NUT-0269	NUT	4
21	191086 01	GEARBOX BRACKET	1	54	WSH-0018	WASHER	4
22	190332 01	SKID ASSY	2				
23	190119 05	WASHER	2				
24	190449 01	RUNNER ASSY RH	1				
25	190499 02	RUNNER ASSY LH	1				
26	190119 04	GEARBOX MTG WASHER	4				
27	BSH-1530	BUSH	4				
28	BSH-3070	BUSH	4				
29	BRG-2020	BEARING	1				
30	NIP-0051	NIPPLE	2				
31	HSS-0191	SCREW	8				
32	BLT-2247	BOLT	4				
33	WSH-0065	WASHER	14				

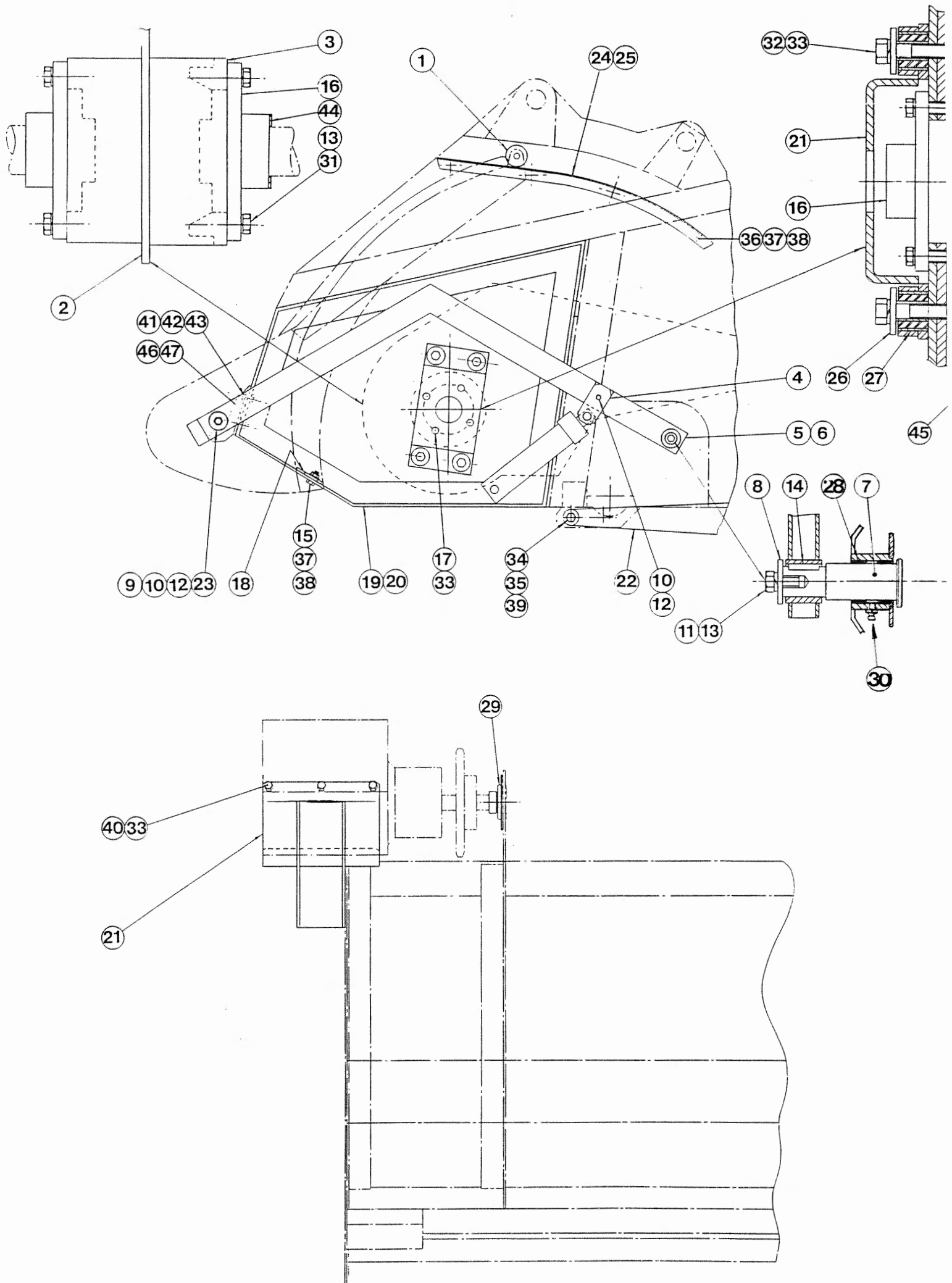

ASSEMBLY PARTS



Shelbourne Reynolds Engineering Limited



ASSY NUMBER: 196034 01

ASSY DESCRIPTION: DRIVE KIT (UNIVERSAL)

ITEM	PART NO	DESCRIPTION	QTY	ITEM	PART NO	DESCRIPTION	QTY
1	HSS-0238	BOLT	6				
2	NUT-0170	NUT	6				
3	WSH-0065	WASHER	6				
4	HSS-0140	BOLT	6				
5	NUT-0164	NUT	6				
6	WSH-0058	WASHER	6				
7							
8	K1008050	KEY	2				
9	K1008045	KEY	1				
10	K1008025	KEY	1				
11	BRG-3220	BEARING	2				
12	HSS-0191	BOLT	7				
13	NUT-0265	NUT	6				
14	WSH-0015	FLAT WASHER	6				
15	190548 01	RETAINING WASHER	1				
16	WSH-0061	WASHER	1				
17	BSH-2268	TAPER LOCK BUSH	2				
18	191112 01	IDLER SUPPORT	1				
19	BSH-3030	BUSH	1				
20	191106 01	BUSH	2				
21	190119 07	RETAINING WASHER	1				
22	BLT-2316	BOLT	1				
23	WSH-0024	WASHER	3				
24	NUT-0271	NUT	3				
25	191111 01	CHAIN KEEP	1				
26	191113 01	IDLER SPACER	1				
27	191117 01	IDLER SPROCKET	1				
28	BRG-1995	BEARING	1				
29	CIR-0470	CIRCLIP	1				
30	BLT-2312	BOLT	2				
31	SPG-0050	SPRING	1				
32	191122 01	SPRING TENSIONING BRKT	1				

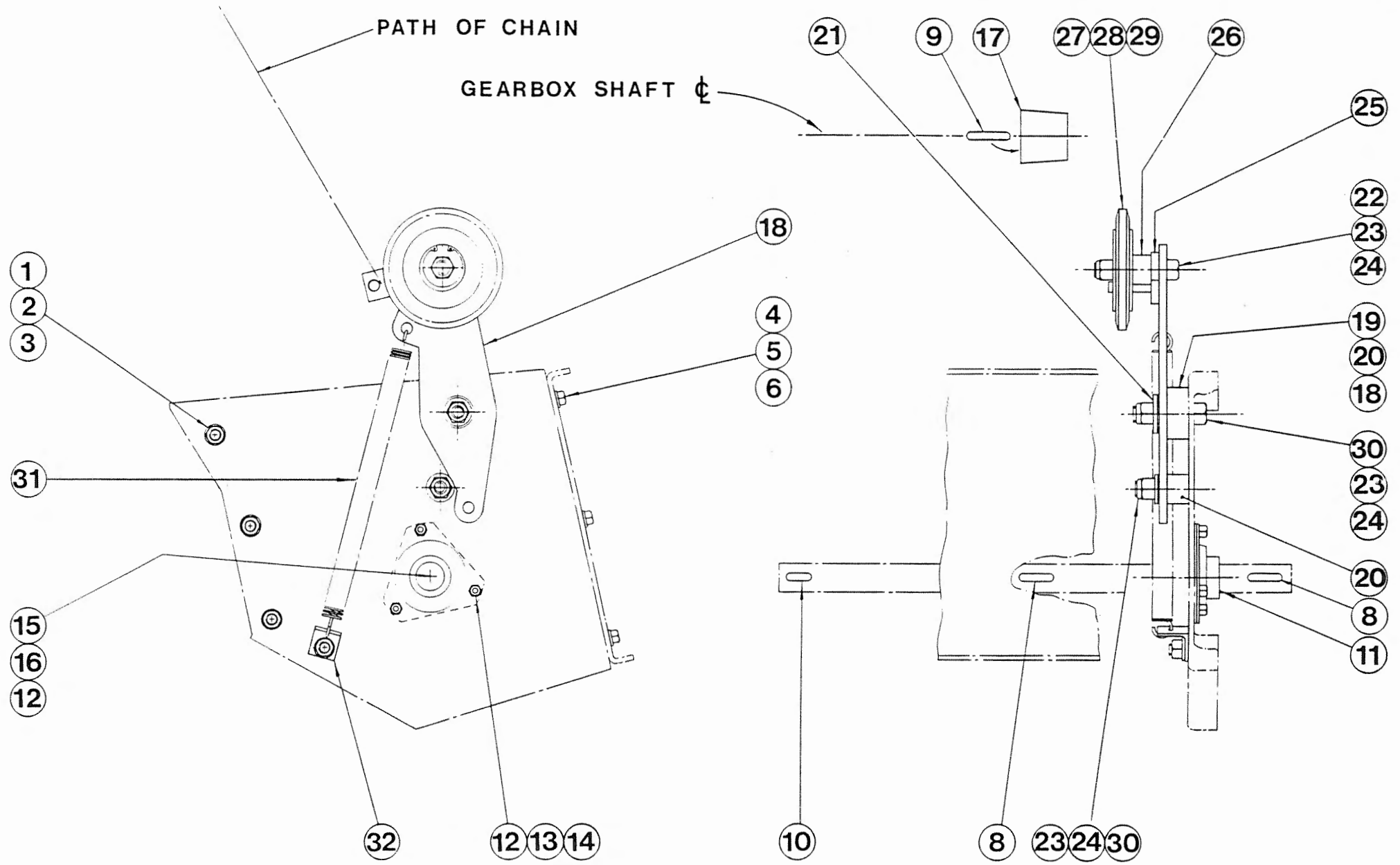

DRIVE KIT (UNIVERSAL)



Shelbourne Reynolds Engineering Limited



ASSY NUMBER:

196035 01

ASSY DESCRIPTION:

HYDRAULICS (3.0M)

ITEM	PART NO	DESCRIPTION	QTY	ITEM	PART NO	DESCRIPTION	QTY
1	190030 01	HYDRAULIC RAM	2				
1A	SEA-0280	SEAL KIT					
2	190859 01	HYDRAULIC FITTING	2				
3	190859 02	RESTRICTOR	2				
4	WSH-1010	DOWTY WASHER	2				
5	2528 135	HOSE	2				
6	FIT-0047	HYD FITTING	2				
7	191173 01	STEEL PIPE LH	1				
8	191173 02	STEEL PIPE RH	1				
9	FIT-0214	HYD FITTING	2				
10	RP-100363	STEEL PIPE	2				
11	FIT-0212	HYD FITTING	2				
12	RP-102315	STEEL PIPE	1				
13	FIT-0213	HYD FITTING	2				
14	FIT-0215	HYD PLUG FITTING	1				
15	FIT-0051	NUT	1				
16	FIT-1000	PETA CLAMPS	4				
17	SCW-0086	SCREW	8				

L.H.

== RIGID STEEL PIPE.  
— FLEXIBLE HOSE.

R.H.

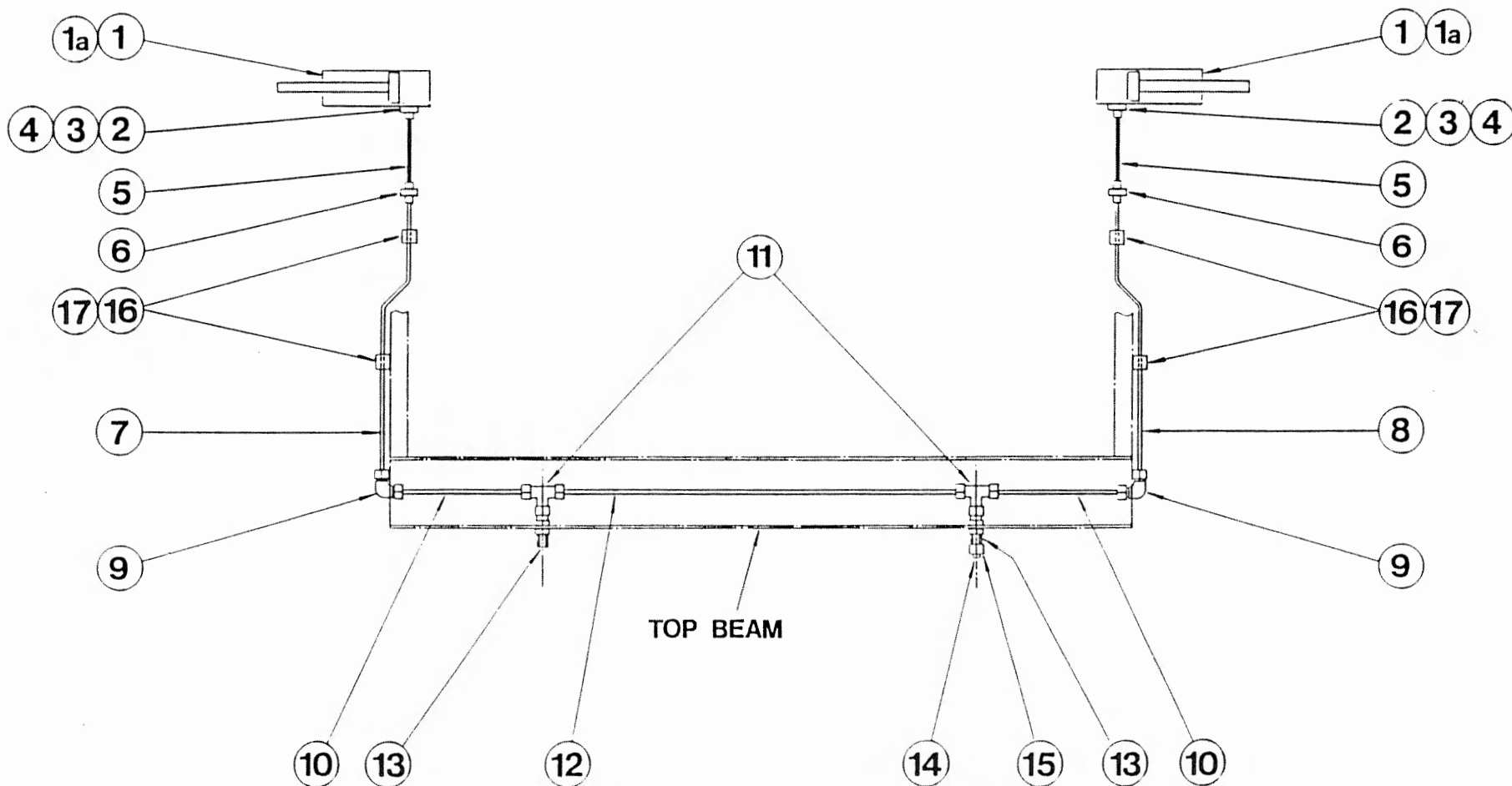

**NOTE;**  
**SEE RELEVANT ADAPTOR PLATE ASS'Y FOR THE TYPE OF QUICK**  
**RELEASE FITTING TO CONNECT WITH ITEM 13.**

HYDRAULICS.







Shelbourne Reynolds Engineering Limited



ASSY NUMBER:

196036 01

ASSY DESCRIPTION:

EMBLEMS & GUARDS

ITEM	PART NO	DESCRIPTION	QTY	ITEM	PART NO	DESCRIPTION	QTY
1	190848 01	EMBLEM	1	34	HSS-0084	SCREW	3
2	190848 02	EMBLEM	1	35	NUT-0260	NUT	2
3	127075 10	EMBLEM	1	36	WSH-0009	WASHER	8
4	127075 12	EMBLEM	6	37	PIN-1088	SPLIT PIN	1
5	190848 03	EMBLEM	1	38	RUB-0151	RUBBER TOGGLE (LARGE)	2
6	190702 01	EMBLEM	1	39	RUB-0154	HINGE PIN (LARGE)	2
7	190702 03	EMBLEM	2	40	RUB-0161	RUBBER TOGGLE (SMALL)	2
8	190702 02	EMBLEM	4	41	RUB-0164	HINGE PIN (SMALL)	2
9	190702 04	EMBLEM	4	42	SCW-4700	SCREW	1
10	190848 06	EMBLEM	1	43	HSS-0086	SCREW	2
11	190848 04	SRE EMBLEM	1	44	WSH-0056	WASHER	4
12a	190847 01	EMBLEM (3.0M)	1	45	WSH-0058	WASHER	3
12b	190847 02	EMBLEM (3.6M)	1				
12c	190847 03	EMBLEM (4.2M)	1				
12d	190847 04	EMBLEM (4.8M)	1				
12e	190847 05	EMBLEM (6.0M)	1				
12f	190847 06	EMBLEM (5.4M)	1				
13	190849 01	EMBLEM (WARNING)	1				
14	190848 05	EMBLEM (CAB)	1				
15							
16							
17	191359 01	IDENTIFICATION PLATE	1				
18	POP-0006	RIVET	4				
19							
20	191366 01	SIDE DEFLECTOR LH	1				
21	191353 01	DRIVE GUARD TOP PLATE	1				
22	191200 01	DRIVE GUARD SUPPORT PLATE	1				
23	191368 01	SIDE DEFLECTOR RH	1				
24	191202 01	TOP COVER RH	1				
25	191360 01	TOP COVER RH	1				
26	BLT-2165	BOLT	4				
27	NUT-0263	NUT	12				
28	HSS-0140	SCREW	8				
29	WSH-0012	WASHER	20				
30	191355 01	COVER	1				
31	191352 01	FRONT DEFLECTOR LH	1				
32	191370 01	GUARD STAY	1				
33	HSS-0135	SCREW	3				



Shelbourne Reynolds Engineering Limited



ASSY NUMBER:

196036 02

ASSY DESCRIPTION:

EMBLEMS & GUARDS WITH WEAR STRIPS

ITEM	PART NO	DESCRIPTION	QTY	ITEM	PART NO	DESCRIPTION	QTY
1	190848 01	EMBLEM	1	34	HSS-0084	SCREW	3
2	190848 02	EMBLEM	1	35	NUT-0260	NUT	2
3	127075 10	EMBLEM	1	36	WSH-0009	WASHER	8
4	127075 12	EMBLEM	6	37	PIN-1088	SPLIT PIN	1
5	190848 03	EMBLEM	1	38	RUB-0151	RUBBER TOGGLE (LARGE)	2
6	190702 01	EMBLEM	1	39	RUB-0154	HINGE PIN (LARGE)	2
7	190702 03	EMBLEM	2	40	RUB-0161	RUBBER TOGGLE (SMALL)	2
8	190702 02	EMBLEM	4	41	RUB-0164	HINGE PIN (SMALL)	2
9	190702 04	EMBLEM	4	42	SCW-4700	SCREW	1
10	190848 06	EMBLEM	1	43	HSS-0086	SCREW	2
11	190848 04	SRE EMBLEM	1	44	WSH-0056	WASHER	4
12a	190847 01	EMBLEM (3.0M)	1	45	WSH-0058	WASHER	3
12b	190847 02	EMBLEM (3.6M)	1	46	191605 01	GUARD WEAR STRIP LH	1
12c	190847 03	EMBLEM (4.2M)	1	47	191606 01	GUARD WEAR STRIP LH	1
12d	190847 04	EMBLEM (4.8M)	1	48	191607 01	GUARD WEAR STRIP LH	1
12e	190847 05	EMBLEM (6.0M)	1	49	191608 01	GUARD WEAR STRIP LH	1
12f	190847 06	EMBLEM (5.4M)	1	50	191612 01	GUARD WEAR STRIP RH	1
13	190849 01	EMBLEM (WARNING)	1	51	191613 01	GUARD WEAR STRIP RH	1
14	190848 05	EMBLEM (CAB)	1	52	POP-0006	POP RIVET	48
15							
16							
17	191359 01	IDENTIFICATION PLATE	1				
18	POP-0006	RIVET	4				
19							
20	191366 01	SIDE DEFLECTOR LH	1				
21	191353 01	DRIVE GUARD TOP PLATE	1				
22	191200 01	DRIVE GUARD SUPPORT PLATE	1				
23	191368 01	SIDE DEFLECTOR RH	1				
24	191202 01	TOP COVER RH	1				
25	191360 01	TOP COVER RH	1				
26	BLT-2165	BOLT	4				
27	NUT-0263	NUT	12				
28	HSS-0140	SCREW	8				
29	WSH-0012	WASHER	20				
30	191355 01	COVER	1				
31	191352 01	FRONT DEFLECTOR LH	1				
32	191370 01	GUARD STAY	1				
33	HSS-0135	SCREW	3				

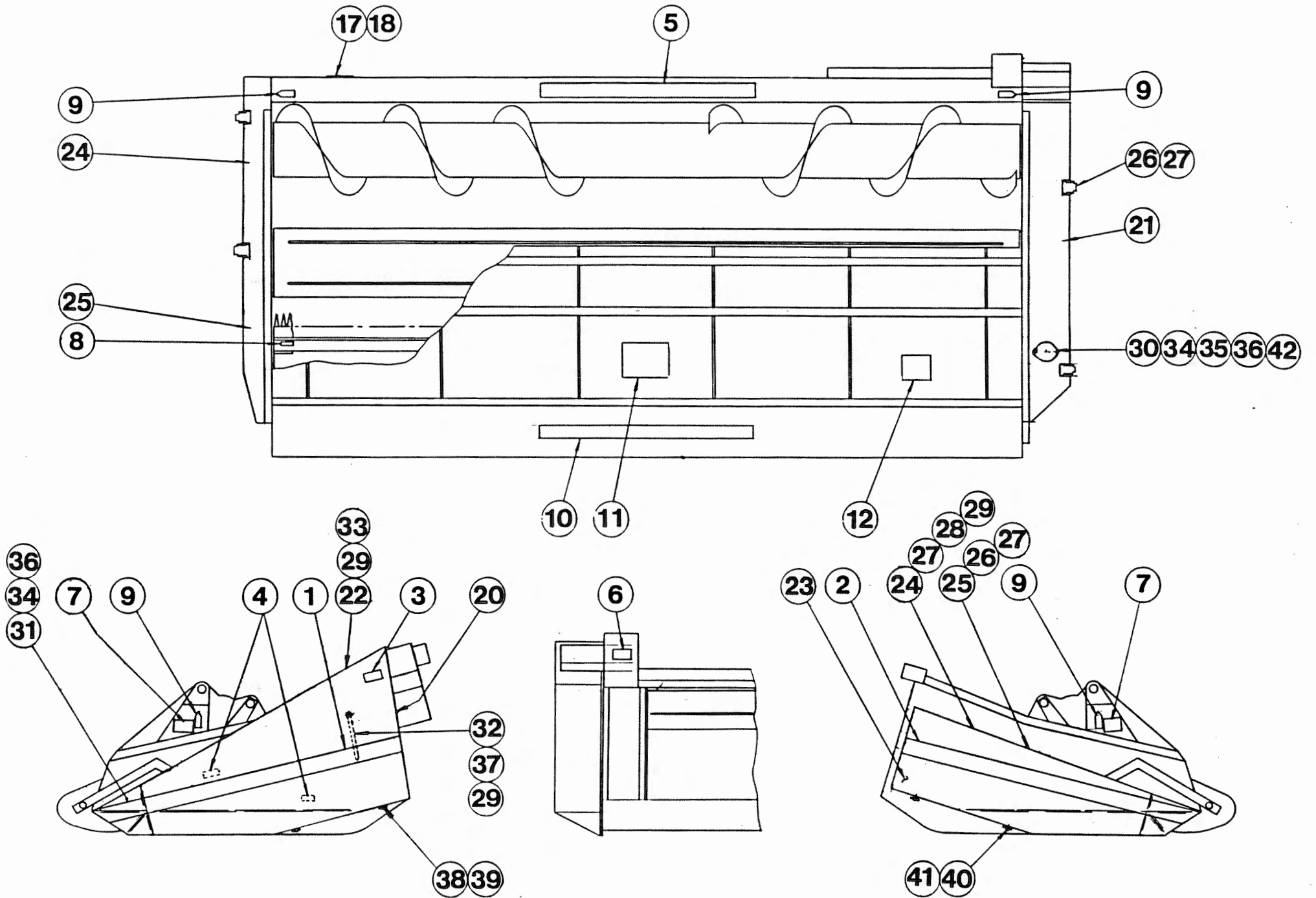

**EMBLEMS AND GUARDS**



Shelbourne Reynolds Engineering Limited



ASSY NUMBER:

196043 02

ASSY DESCRIPTION:

DRIVE COMPONENTS C. T. MKII MULTI PLATE

ITEM	PART NO	DESCRIPTION	QTY	ITEM	PART NO	DESCRIPTION	QTY
1	131014 01	SPROCKET IDLER	3				
2	BRG-1995	BEARING	3				
3	CIR-0470	CIRCLIP	3				
4	190060 06	CONVEYOR IDLER SPINDLE	2				
5	191039 01	IDLER ADJ SCREW	2				
6	191040 01	CONVEYOR IDLER SPACER	2				
7	190057 01	CONVEYOR SPROCKET	1				
8	SCW-4535	SCREW	2				
9	K1008150	KEY	1				
10	NUT-0271	NUT	1				
11							
12	190060 07	AUGER IDLER SPINDLE	1				
13	191040 02	AUGER SPACER	1				
14	CHN-0020	CHAIN	1				
15	CHN-0111	CHAIN JOINER	1				
16							
17							
18							
19							
20							
21	GEA-0090	BEVEL GEARBOX	1				
22							
23	PTO-09002	POWER SHAFT	1				
23A	191392 01	SHEAR BOLT	1				
23B							
23C	NUT-0162	NUT	1				
24							
25	WSH-0018	WASHER	2				
26	BYT-0170	NUT	2				
27	GEA-0080	6 SPEED GB ASSY	1				

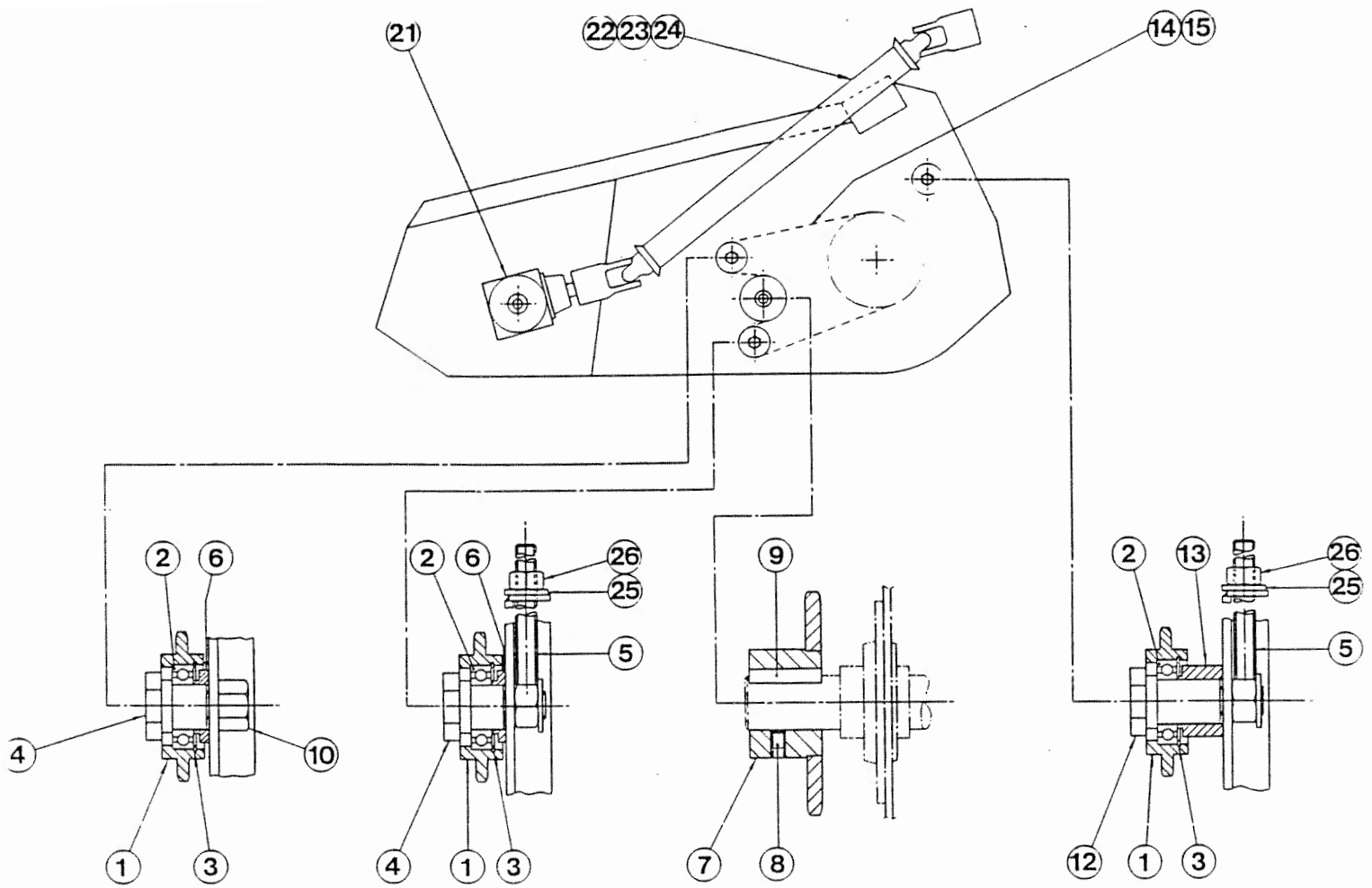

DRIVE COMPONENTS

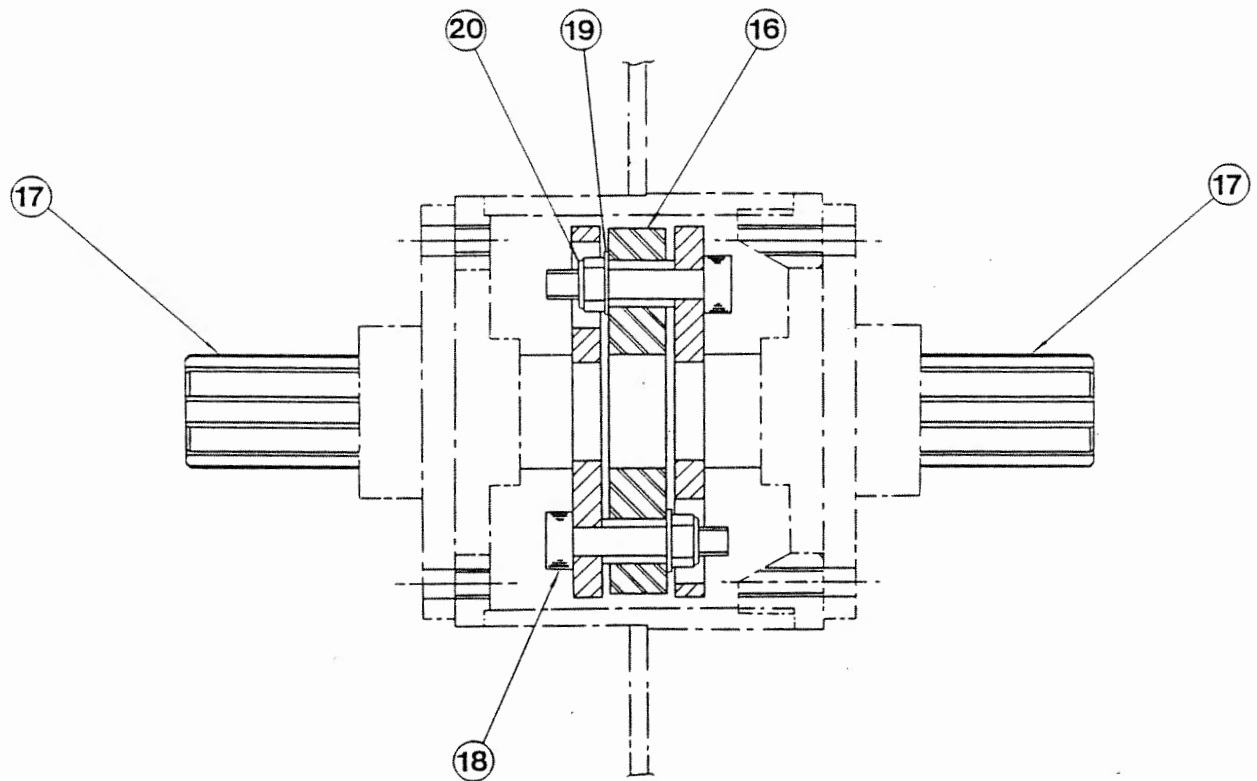

DRIVE COMPONENTS

NOTE - TORQUE ITEMS 24 & 26 TO 77 N/M



Shelbourne Reynolds Engineering Limited



ASSY NUMBER:

196047 01

ASST DESCRIPTION:

AUGER (3.0M) (WITH FLIGHT TIPS)

ITEM	PART NO	DESCRIPTION	QTY	ITEM	PART NO	DESCRIPTION	QTY
1	191	AUGER	1	38	WSH-0065	WASHER	4
2	132019 01	COVER PLATE	1	39	BLT-2135	BOLT	9
3	BRG-4160	BEARING	3	40	NUT-0263	NUT	6
4	190546 01	AUGER CRANK	1	41	BLT-2197	BOLT	3
5	132010 01	BUSH FOR FINGER	15	42	SCW-4960	SCREW	44
6	190547 01	FINGER	14	43	190735 02	BLANKING PLATE	1
7	132011	FINGER PLATE COMCAVE	14	44	NUT-0260	NUT	30
8	132012	FINGER PLATE CONVEX	14	45	WSH-0056	WASHER	14
9	132013	FINGER GUIDE	14	46	PIN-1167	SPLIT PIN14	
10	131095 03	KEY	1	47	SCW-4530	SCREW	2
11	190545 01	AUGER CLAMP	1	48	BLT-3812	COACH BOLT .	4
12	191629 01	AUGER SHAFT	1	49	NUT-0170	NUT	8
13	190208	FINGER ADJUSTER	1	50	BLT-2240	BOLT	1
14	K0807060	KEY	1				
15	191005 02	AUGER ADJUSTER R. H.	1	52	SCW-1975	SCREW	4
16	190585 06	VERTICAL ADJUSTER	2	53	131024 05	SPROCKET	1
17	190585 04	HORIZONTAL ADJUSTER	2	54	WSH-0009	WASHER	14
18	132018 02	AUGER DRIVE SHAFT	1	55	WSH-0018	WASHER	6
19	BRG-0240	BEARING	1	56	PIN-1150	SPLIT PIN	1
20	191005 01	AUGER ADJUSTER L. H.	1				
21	132022 01	SPACER	1				
22	131025	HUB	1				
23	131005	CLUTCH PLATE	2				
24	131055 01	DRIVE PLATE	1				
25	131024 01	SPROCKET	1				
26	131063	SPRING	4				
27	131073 01	SPACER	4				
28	K0807050	KEY	1				
29	191006 01	SPACER	4				
30	BLT-2273	BOLT	4				
31	124048 01	WASHER	4				
32	NUT-0269	NUT	13				
33	NUT-0580	NUT	1				
34	WSH-0030	WASHER	1				
35	HSS-0191	SET SCREW	3				
36	NUT-0265	NUT	6				
37	BLT-2243	BOLT	4				

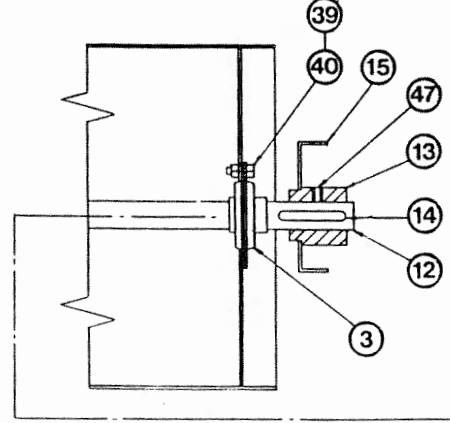
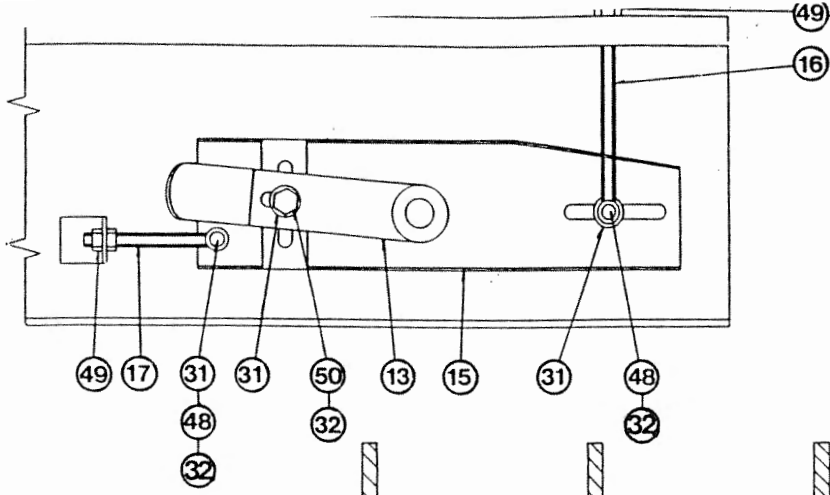

AUGER ASSEMBLY

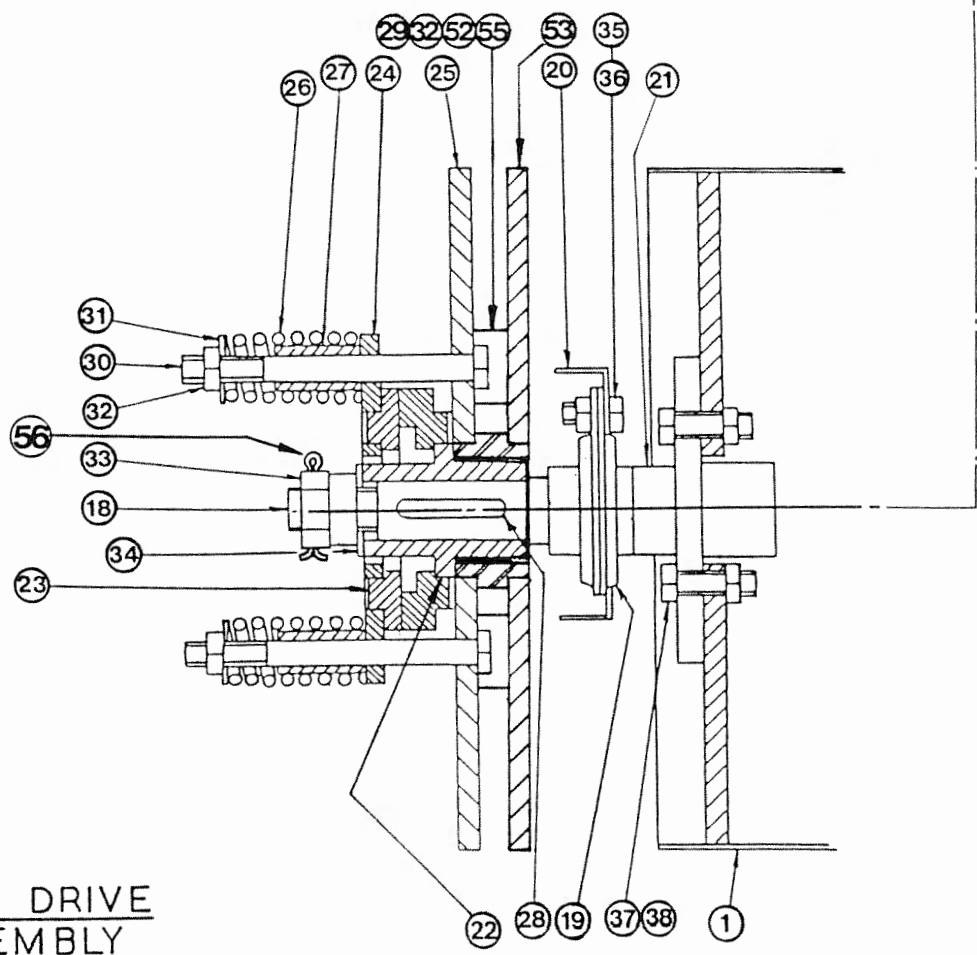
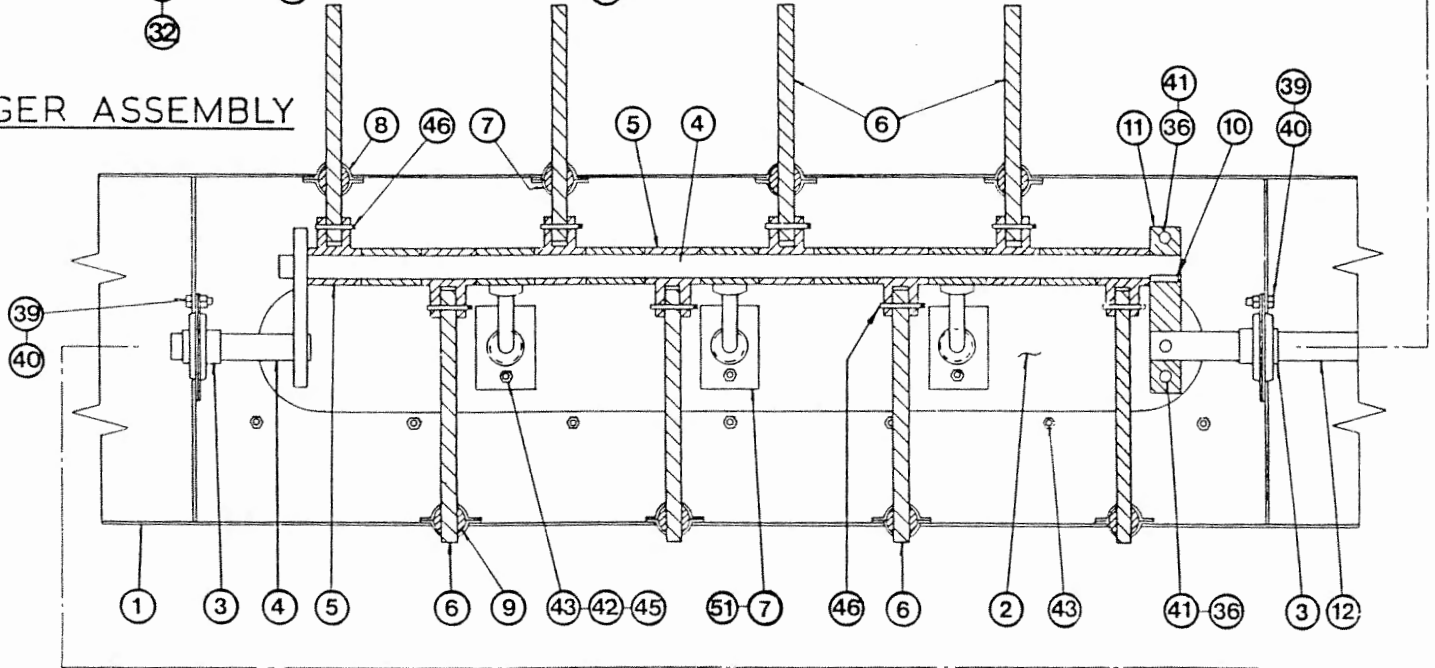

AUGER DRIVE ASSEMBLY



ASSY NUMBER:

GEA-0080

ASSY DESCRIPTION: 6 SPEED GEARBOX ASSY (FRAM1989)

ITEM	PART NO	DESCRIPTION	QTY	ITEM	PART NO	DESCRIPTION	QTY
1	GEA-1203	GEARBOX CASING	1				
2	GEA-1102	INPUT SHAFT	1				
3	GEA-1204	SEAL HOUSING	1				
4	SEA-0550	SEAL	1				
5	BRG-6600	BEARING	1				
6	BRG-6601	BEARING	2				
7	CIR-3800	CIRCLIP	3				
8	CIR-2700	CIRCLIP	3				
9	GEA-1103	LAYSHAFT	1				
10	GEA-1002	BEVEL GEAR	1				
11	BRG-6800	BEARING	1				
12							
13	HSS-0194	BOLT	14				
14	WSH-0061	WASHER	14				
15	GEA-1206	REMOVABLE COVER	1				
16	GEA-13-1	REMOVABLE COVER GASKET	1				
17	SCW-4750	WING BOLT	3				
18	WSH-1310	WASHER	3				
19	FIT-0252	PLUG	1				
20	FIT-0218	PLUG	1				
21	WSH-1027	SEAL WASHER	1				
22	GEA-1072	CHANGE GEAR	1				
23	GEA-1073	CHANGE GEAR	1				
24	GEA-1074	CHANGE GEAR	1				
25	GEA-1075	CHANGE GEAR	1				
26	GEA-1076	CHANGE GEAR	1				
27	GEA-1077	CHANGE GEAR	1				
28	GEA-1207	OUTPUT HOUSING	1				
29	GEA-1104	OUTPUT SHAFT	1				
30	GEA-1003	BEVEL GEAR	1				
31	BRG-6000	BEARING	1				
32	BRG-5700	BEARING	1				
33	SEA-0560	SEAL	1				
34	NUT-0590	CASTLE NUT	1				
35	PIN-1168	COTTER PIN	1				
36	GEA-1302	GASKET SET	1				

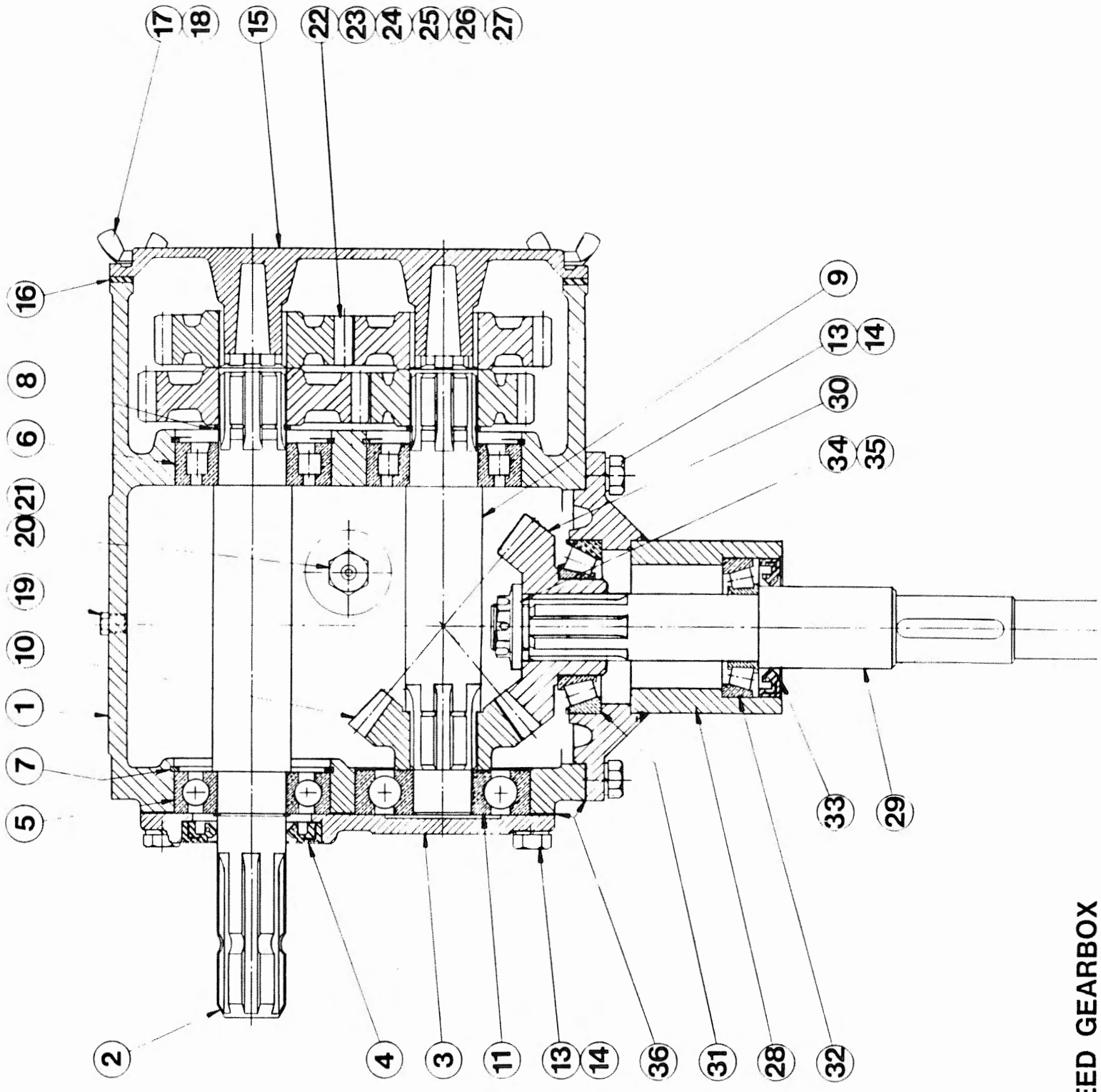

SIX SPEED GEARBOX



Shelbourne Reynolds Engineering Limited



ASSY NUMBER:

GEA-0090

ASSY DESCRIPTION: BEVEL GEARBOX ASSY (FROM 1989)

ITEM	PART NO	DESCRIPTION	QTY	ITEM	PART NO	DESCRIPTION	QTY
1	GEA-1200	BEVEL GEARBOX CASING	1				
2	GEA-1201	BEARING & SEAL HOUSING	1				
3	BRG-6001	BEARING	2				
4	BRG-6002	BEARING	1				
5	SEA-0570	SEAL	2				
6	GEA-1100	OUTPUT SHAFT	1				
7	GEA-1000	BEVEL GEAR	1				
8	GEA-1202	INPUT HOUSING	1				
9	GEA-1101	INPUT SHAFT	1				
10	GEA-1001	BEVEL GEAR	1				
11	BRG-5710	BEARING	1				
12	SEA-0562	SEAL	1				
13	GEA-1300	GASKET	1				
14	FIT-0251	LEVEL PLUG	1				
15	HSS-0140	BOLT	12				
16	WSH-0058	WASHER	12				
17	HSS-0191	BOLT	6				
18	WSH-0061	WASHER	6				
19	NUT-0590	NUT	1				
20	PIN-1168	COTTER PIN	1				
21	FIT-0218	PLUG	1				
22	WSH-1027	SEAL WASHER	1				

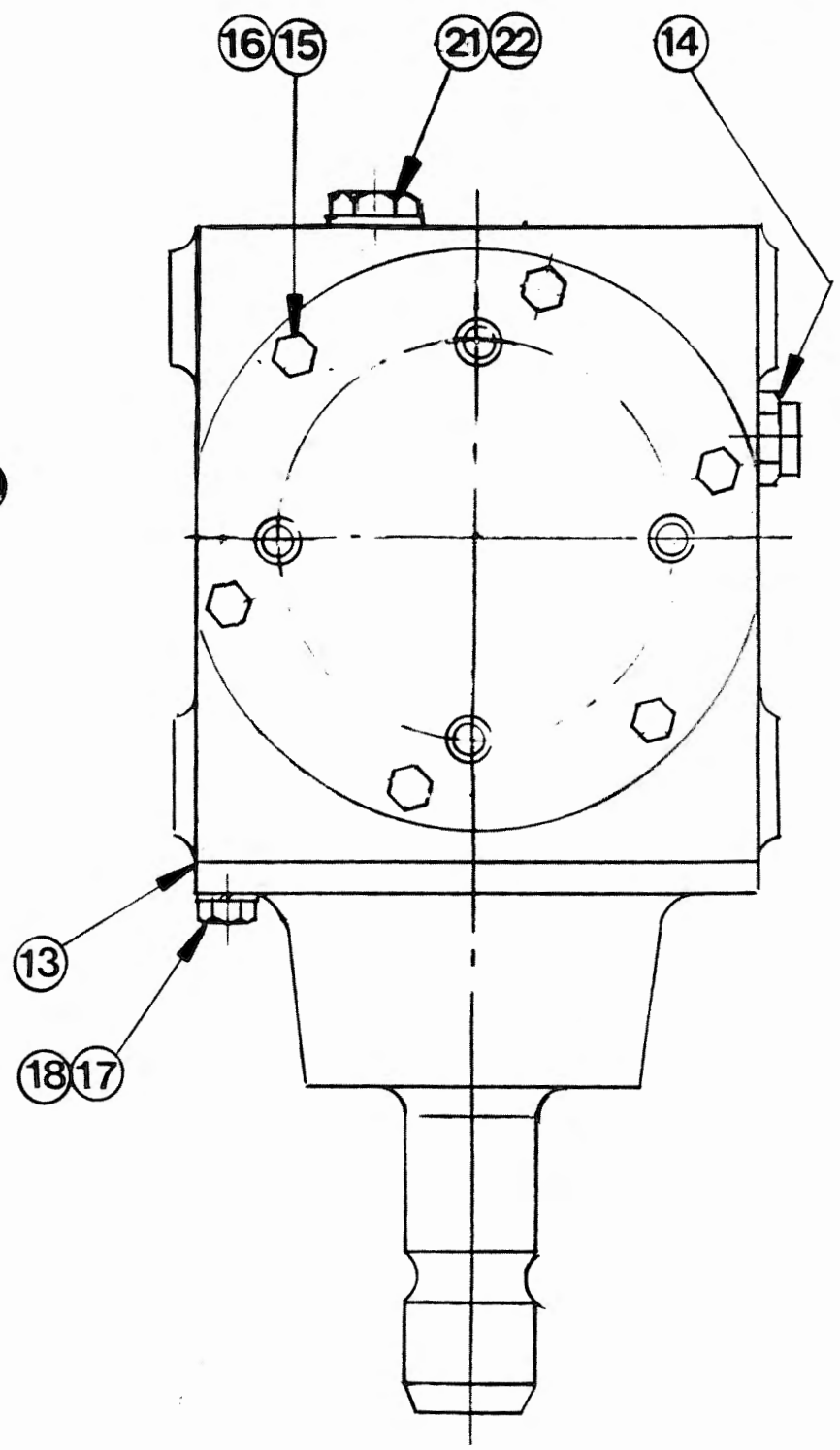
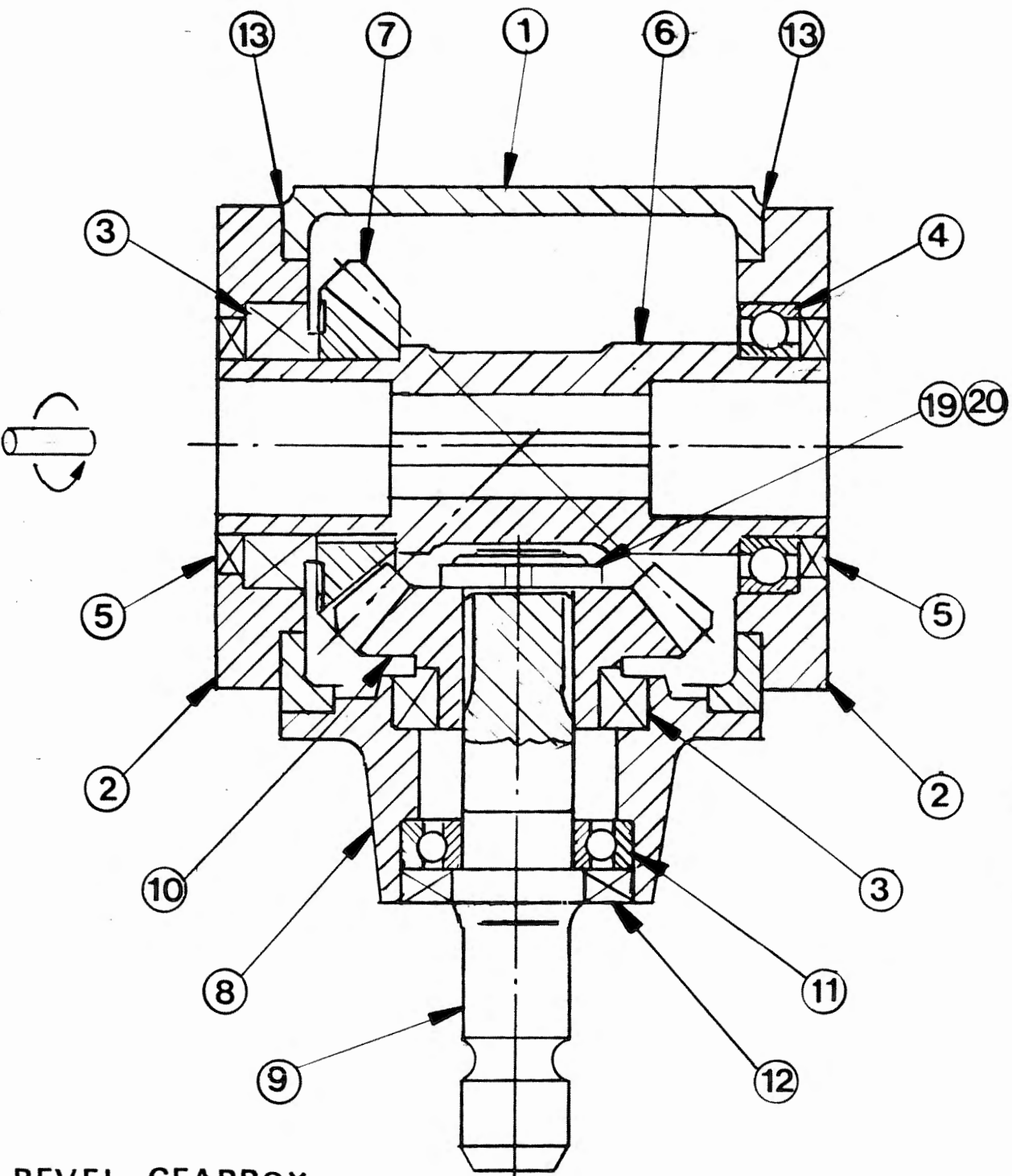

BEVEL GEARBOX